

MAGNETIC CIRCUIT HEATING METHOD FOR SYNCHRONOUS GENERATOR

Mihail Digalovski^{1}, Krste Najdenkoski², Goran Rafajlovski³*

^{1,2,3} “Ss. Cyril and Methodius” University,
Faculty of Electrical Engineering and IT, Skopje

³SRH University of applied science, Berlin

^{1,2,3}North Macedonia, ³Germany

* Corresponding Author, e-mail: mihaild@feit.ukim.edu.mk

Abstract: This paper presents the examination of the magnetic core of a large synchronous generator, by the method of indirect heating through an improvised winding. The test results, the criteria for assessing the operating condition of the generator magnet circuit, as well as the analytical calculations for the improvised winding, which is connected through a special connection to the auxiliary transformers, are shown. Electromagnetic simulations were also performed to check the required value of the magnetic flux density in the generator core.

Key words: Hot spot temperature, Specific power losses, Synchronous generator, Infrared camera.

1. INTRODUCTION

The active part of the synchronous generator which comprises a magnetic cores and windings of the stator and rotor during, exploitation is exposed to: electrical, magnetic, mechanical and thermal stresses. Stator magnetic core is an important part of the synchronous generator, and if eventually damages are not detected during production or repair activities may lead to serious failures during exploitation. Therefore, it is necessary magnetic core to be always in good operation condition.

Therefore, it is recommended to regularly check the insulation condition, to avoid possible damage such as core burning or damage of the bar insulation. Today, one of the methods to detect possible damages is examination of stator magnetic core with an improvised winding, ac voltage excited with a frequency of 50 Hz, with such value to achieve magnetic density flux about 1 (T) in the yoke of stator magnetic core.

Examination of stator magnetic core comprising: examination the existence of possible abutments between isolated magnetic sheet or damages to the interlayer insulation, measuring of heating temperature the elementary parts of the magnetic core, and determination of the specific power losses through the measurement magnetic core power losses. They are essential parameters for determining of its operation condition.

2. CALCULATION AND CONSTRUCTION OF EXCITATION AND MEASURING WINDING

The tests and measurements of the stator magnetic core is performed with excitation winding connected to regulated AC voltage (it is possible), such value to achieve magnetic flux density in the range of 0.8 to 1.5 T.

Stator magnetic core is used as a transformer magnetic core on which is wrapped excitation (primary) and measurement (secondary) winding. Excitation winding consist several turns of rubber cable, which is connected to a regulated AC electrical source with 50 Hz frequency, in order to achieve different values of magnetic flux density.

The required number of turns of the excitation and measuring winding and the approximate electrical source power are determined on the basis of calculation, on certain dimensions and the magnetization characteristics of the magnetic sheets from which it is produced magnetic core.

From theory, number of turns of excitation windings is determined by the equation:

$$W_v \approx \frac{U_v}{4,44 \cdot f \cdot B_i \cdot S_{Fev1}} \quad (1)$$

and the number of the measuring winding, if neglect the voltage drop, according to the equation:

$$W_k = W_v \frac{U_k}{U_v} \quad (2)$$

where is: U_v – applied AC voltage to excitation winding in (V); U_k - induced voltage in the measuring voltage (V); f - frequency of the applied voltage in (Hz); B_i - magnetic flux density in (T); S_{Fev1} – stator magnetic core axial effective cross-section in (m²).

For determining the magnetic flux density in the crown of stators magnetic core serves the measuring winding, wherein the magnetic flux density B_i (T) during the test is determined by the equation:

$$B_i = \frac{U_k}{4,44 \cdot f \cdot W_k \cdot S_{Fev1}} \quad (3)$$

The duration of the test as recommended is 90 minutes with the magnetic flux density of 1T and frequency of 50 Hz. If magnetic flux density and frequency is

different from the reference and the nominal value, is making adjustments to the examination time.

Electrical source apparent power needed to perform the examination with reference induction $B_r=1\text{T}$ and frequency of 50 Hz, is determined by the equation:

$$S_v = U_v \cdot I_v \quad (4)$$

it has two components:

$$S_v = P_v + jQ_v \quad (5)$$

The active component (P_v) is calculated from the size of electric power losses in excitation winding (p_k) and power losses in the stator magnetic core (p_{Fe}) and according to the equation:

$$P_v = p_k + p_{Fe} \quad (6)$$

Electric power losses in excitation winding is calculated by the equation $p_k = I_v^2 r_k$, and are very small compared to the power losses in the magnetic core, due to the small active resistance r_k of the excitation winding and approximately:

$$P_v = p_{Fe} \quad (7)$$

Specific power losses in stator magnetic core (p_{Fe}) at magnetic flux density of 1T and frequency of 50 Hz, can be calculated by the equation:

$$p_{Fe} = p_{Fe1/50} \cdot m_{Fev1} \quad (8)$$

In the equation (8) $p_{Fe1/50}$ represent specific power losses of magnetic sheet at magnetic flux density of 1T and frequency of 50 Hz.

The crown of stator magnetic core mass is:

$$m_{Fev1} = \gamma_{Fe} \cdot S_{Fev1} \cdot (D_N - h_{v1}) \quad (9)$$

Reactive power that takes excitation winding from the electrical source is:

$$Q_v = Q_\sigma + Q_\mu \quad (10)$$

where Q_σ is a reactive power due leakage magnetic flux and Q_μ is reactive power which magnetizing the stator core.

If neglected leakage magnetic flux in excitation winding, the equation (10) approximately passes to:

$$Q_v \approx Q_\mu = E_v \cdot I_\mu \quad (11)$$

Induced voltage in excitation winding (E_v) is lower than the applied voltage (U_v) for the voltage drops in excitation winding impedance ($Z_k = r_k + jx_k$). If that voltage drop is neglect, it can take approximately:

$$Q_\mu \approx U_v \cdot I_\mu \quad (12)$$

Magnetization current of a stator magnetic core needed to achieve the reference magnetic flux density B_r , approximately can be calculated by the equation:

$$I_\mu \approx \frac{(D_N - h_{v1}) \cdot \pi \cdot H_m}{\sqrt{2} \cdot W_v} \approx \frac{(D_N - h_{v1}) \cdot \pi \cdot \Phi_m}{\sqrt{2} \cdot W_v \cdot \mu \cdot S_{Fev1}} \approx \frac{(D_N - h_{v1}) \cdot \pi \cdot B_r}{\sqrt{2} \cdot W_v \cdot \mu} \quad (13)$$

where: H_m - magnetic field strength by the magnetization characteristic to achieve at magnetic flux density B_r (T); ϕ_m - magnetic flux in the stator magnetic core at magnetic flux density B_r (T); μ - magnetic sheets permeability at reference magnetic flux density B_r (T) excitation.

3. CRITERIA FOR ASSESING THE OPERATING CONDITION OF STATOR MAGNETIC CORE

To assess the operation condition of the stator magnetic core of synchronous generator, in practice apply the following criteria:

a) **The hot spot temperature rises** of the elementary part of stator magnetic core, measured after 90 minutes from start of the test and reduced to reference magnetic flux density of 1T and a nominal frequency of 50 Hz, **cannot exceed the value of $\Theta = 25$ (K)**.

b) **Maximal difference between temperatures of the hot spot and cold spot elementary part of the stator magnetic core**, measured after 90 minutes from start of the test and reduced to reference magnetic flux density of 1T and a nominal frequency of 50 Hz, **cannot exceed the value $\Delta\Theta = 15$ (K)**.

c) **The specific power losses in the stator magnetic yoke**, reduced to reference magnetic flux density of 1T and a nominal frequency of 50 Hz, **cannot exceed the reference value of $p_{Fe1/50} \leq 2,5$ (W/kg)**.

In case the results of temperature measurements of the stator magnetic core not meet the above-mentioned criteria, it is considered defective condition and according to measured temperatures are classified according to the recommendations of VDE (Verband der Elektrotechnik, Elektronik und Informationstechnik) [1].

Basic data of examined synchronous generator are presented in Table 1.

Table 1. Synchronous generator basic data

Manufacturer	<i>DOLMEL – Wrocław, Poland</i>
Type	<i>TGH – 120</i>
Year	<i>1977</i>
Nominal power	<i>150 (MVA) / 120 (MW)</i>
Nominal voltage	<i>13800 (V)</i>
Nominal current	<i>6276 (A)</i>
Nominal frequency	<i>50 (Hz)</i>
Number of poles	<i>$2p=2$</i>
Nominal speed	<i>3000 min^{-1}</i>
Nominal power factor	<i>0,8</i>

4. ELECTRIC CIRCUIT AND TEST PROCEDURE

Electrical circuit for performing the tests and measurements, with the necessary devices and instruments is given in Figure 1, and the labels are:

(1) – electrical source of adjustable AC voltage, P – switch and O – fuses (As a source of AC voltage using two power transformers for own consumption connected to each other as shown in Figure 1, because there was no possibility of voltage regulation in wide area)

(2) - number of turns of excitation winding ($W_v = 3$ tur.).

(3) - number of turns of measuring winding ($W_k = 1$ tur.).

(4) - amperemeter for excitation current measurement I_v (A)

(5) - digital wattmeter for power measurement (W)

(6) - voltmeter to measure the induced voltage of the measuring winding (V_k)

(7) - voltmeter to measure the applied voltage to excitation winding (V_v)

(8) - frequencies (F)

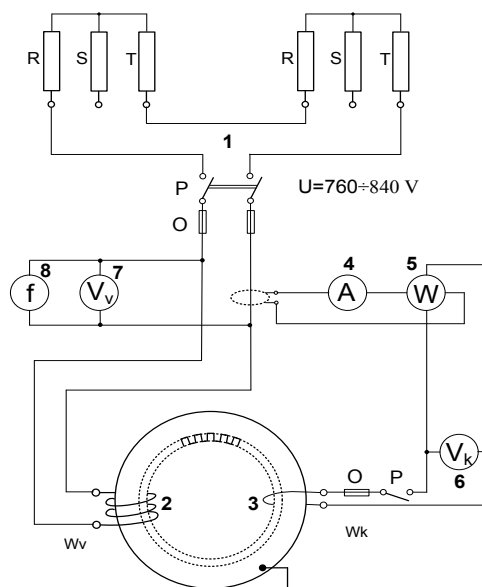

Fig. 1. Electrical circuit for stator magnetic core test

Frequency, voltage of measuring winding, current in the excitation winding and power losses are measured using power analyser OMNIQUANT. Heating temperatures of the elementary parts of the the magnetic core segments are measured using a thermal imager Testo 881-2.

The value of the magnetic flux density is accrual determined from the measured value of the induced voltage in the measuring winding, according to the equation (3).

Power losses in stator magnetic core (p'_{Fe}), which are calculated at reference induction ($B_r=1T$) and reference frequency ($f = 50Hz$), amounts:

$$P_{Fe} = P'_{Fe} \cdot \left(\frac{B_r}{B_i} \right)^2 \cdot \left(\frac{f_r}{f_i} \right)^{1,3} \quad (13)$$

Specific power losses of magnetic sheets, calculated at reference induction and frequency reference are:

$$P_{Fe1/50} = \left(\frac{P_{Fe}}{m_{Fev1}} \right) \quad (15)$$

Once implemented the electric circuit for test begins with measurement.

After 15 minutes of the test start is checked visually magnetic core elementary parts heating and running the first thermal imaging.

During the tests in certain time intervals are measured: applied and induced voltage, current, frequency, power and hot spot temperatures of elementary parts of stator magnetic core, using a thermal imager.

Using the power analyser is measuring the current values of the voltages and currents in the measuring and excitation winding.

The hot spot temperatures of the stator magnetic core that are relevant for assessment of its operating condition is measured on the inner surface of the stator.

Stators magnetic core has 72 slots. Stators inner surface of the magnetic core is divided into four measuring sectors, two by the turbine side and two by the excitation side.

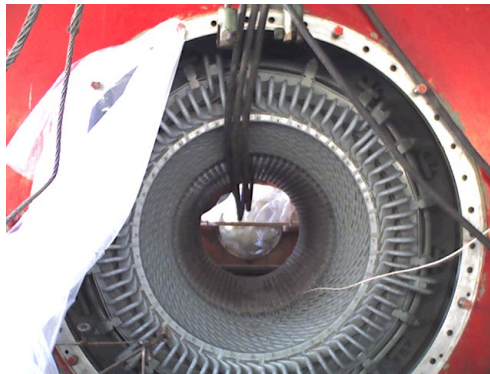

Fig.2. Stator of the generator with excitation and measuring winding

5. PRESENTATION AND ANALYSIS OF RESULTS

In following modeling the Synchronous Generator stator magnetic circuit by means of ANSOFT software package is performed. The simulation proves the value of magnetic flux density inside the stator magnetic core. It is shown that the obtained simulation values are matching very well the results coming out from analytical calculations. The geometrical dimensions of the model are in line with the actual size of the generator. Figures 3 and 4 provides a two-dimensional and

three-dimensional display of the generator. On Fig.3 cross section of the SG viewed from the excitation is presented, while Fig.4 shows four stator sectors for the appropriate thermal recording.

The figure 5 shows the distribution of magnetic flux density in the magnetic core of the stator. In the same picture is a spectrum of magnetic flux density and their corresponding values expressed in the unit - Tesla (T). In cross-section is shown excitation winding Wv.

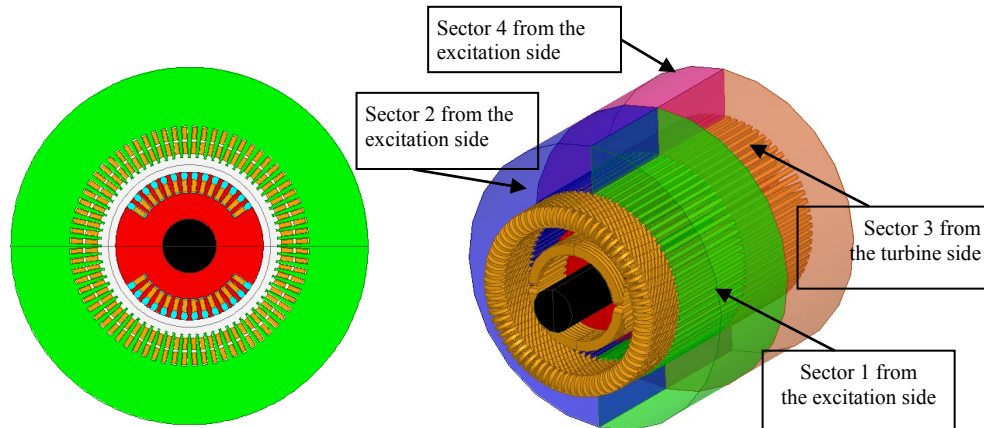

Fig. 3. Cross-section of the synchronous generator, viewed by the excitation side

Fig. 4. Three-dimensional view, by the excitatin side

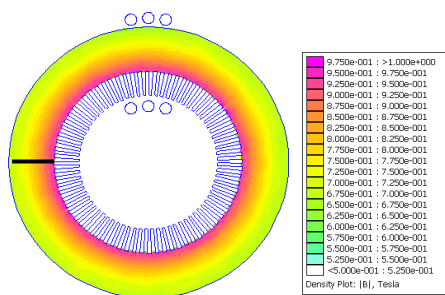

Fig. 5. Stator magnetic flux distribution

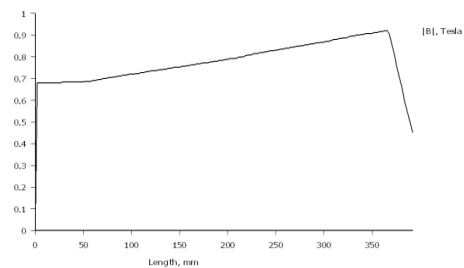

Fig.6 Bm along the cross-section of the stator

In the figure 6 is presented distribution of magnetic flux density B_m along the cross-section of the stator without teeth and slots. The graph shows that the average value of the magnetic induction along the cross-section is about 0,76 (T). The length of the cross section of the stator without teeth and slots is 400 (mm). The line along which is made graphic representation of B_m is given in figure 5 (black line).

The results of the measurements and the calculated values for specific power losses p_{Fe} at 1 T and 50 Hz are shown in Table 2, also and criteria(c) $p_{Fe} 1/50$ in W/kg.

Table 2. Specific power losses p_{Fe}

Time	U_v	U_k	I_v	B_i	p_{Fe} (measured)	p_{Fe} (for 1 T and 50 Hz)	Criteria
							c)
(h)	(V)	(V)	(A)	(T)	(W)	[W]	(W/kg)
12:10	770,80	253,2	195,7	0,736	55000	101426	1,94
12:25	771,40	258,8	196,6	0,737	55200	101715	1,95
12:40	790,20	259,3	219,5	0,753	57900	102123	1,95
12:55	791,20	258,8	220,1	0,754	58000	101905	1,95
13:10	790,30	259	220,9	0,753	58000	102299	1,96
13:25	790,80	259,1	221,1	0,754	58000	102141	1,95
13:40	791,10	259,5	221,6	0,754	58100	102238	1,96
13:55	792,20	260	224	0,755	58400	102450	1,96
14:10	794,70	260	227,8	0,756	58600	102405	1,96
14:25	794,40	260	227,6	0,756	58700	102580	1,96
14:40	795,10	260,2	229	0,756	58800	102755	1,97
14:55	795,00	260,8	230,6	0,757	58900	102772	1,97
15:10	797,50	260,8	231,9	0,759	59100	102647	1,96
15:25	797,70	253,2	233,7	0,759	59200	102820	1,97

Test start time is 12:10.

Thermograms from thermal imaging of hot spot temperatures for stator sectors marked from 1 to 4 carried out at start of the test at 12:10 are illustrated in figures 7, 8, 9 and 10.

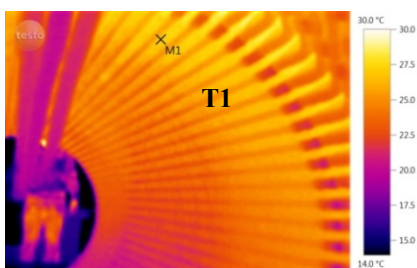

Fig. 7. Maximum temperature in 12:10 in the sector No. 1

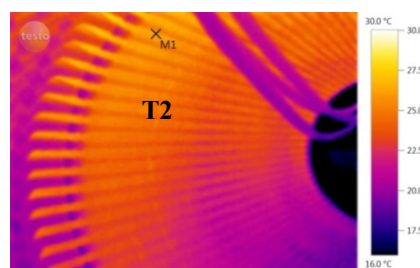

Fig. 8. Maximum temperature in 12:10 in the sector No. 2

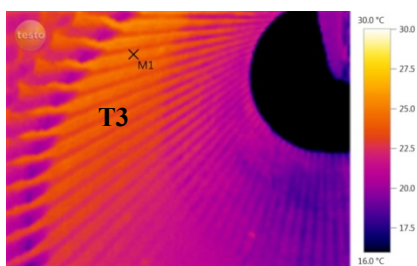

Fig. 9. Maximum temperature in 12:10 in the sector No. 3

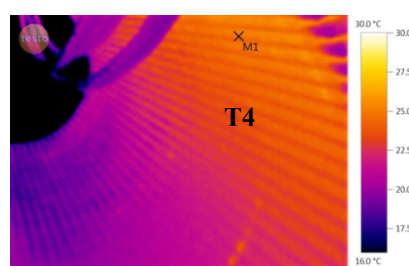

Fig. 10. Maximum temperature in 12:10 in the sector No. 4

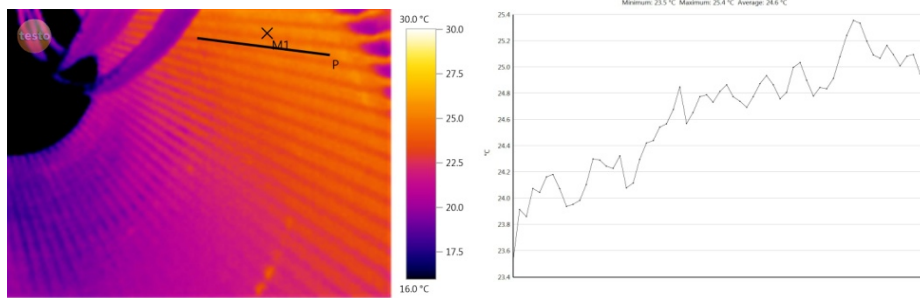

Fig.11. Temperature distribution along the one slot in a sector No. 4.

The thermograms of sectors No-1, -2, -3 and No.4, taken at 12:10 o'clock registered very small areas as points with hot spot temperatures compared to the temperatures to the rest of the sector, which is taken as a reference temperature. These increased temperatures are in the limits of 5,5°C to 7°C.

At 15:25 finished heating stator magnetic core and thermograms of sectors No-1, -2, -3 and No.- 4 taken at 15:25 AM registered areas as small points with hot spot temperature compared to the temperature of the rest of the sector, which it is taken as a reference temperature. These increased temperatures are in the limits of 9,3°C to 10,3°C.

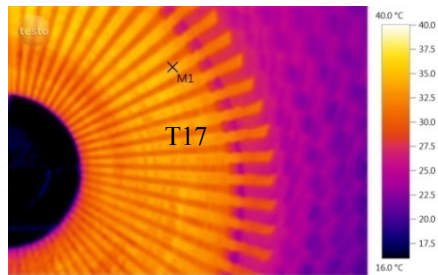

Fig. 12. Maximum temperature in 15:25 in the sector No. 1

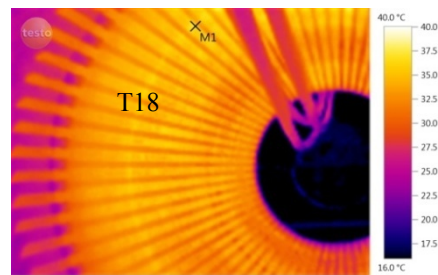

Fig. 13. Maximum temperature in 15:25 in the sector No. 2

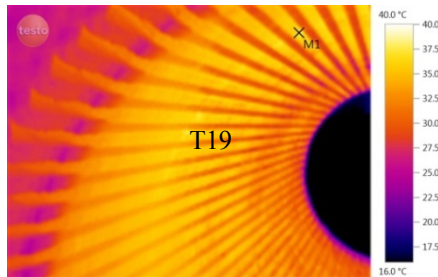

Fig. 14. Maximum temperature in 15:25 in the sector No. 3

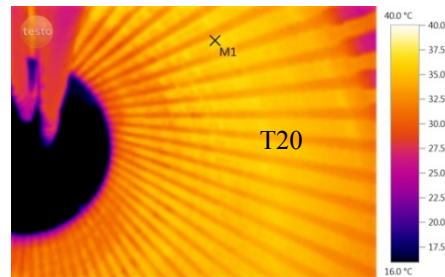

Fig. 15. Maximum temperature in 15:25 in the sector No. 4

Hot spot in the stator magnetic core, located on the teeth between 35th and 36th slot, on sector No. 3 viewed from the turbine side and counted from the first slot at the same side.

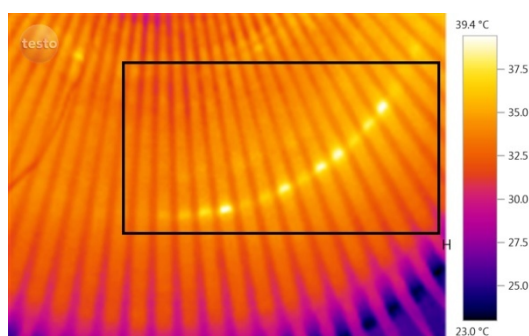

Fig. 16. Hot spot part of stator magnetic core at 15:25 o'clock

Cumulative results of the measured temperatures of stator magnetic core from the start measurements at 12:10 and to the end at 15:25 are given in Table 3. In the table is presented maximum and reference temperature and temperature difference. As can be seen, the hot spot temperature measured at the end of the measurements is 38.2 °C, was measured in the sector No. 3, and temperature difference in relation to the reference temperature is 10.3 °C.

Analysing the results of the tests and measurements given in Table 3, it can be concluded the following:

Table 3. Measured temperatures

Time	S ₃	S ₃ in sectors		□ _{max} (°C)				□ _{max} -□ _r (°C)				□ _{max} -□ _a (°C)				Criteria	
		1/2	3/4	Sector				Sector				Sector				a)	b)
(h)	(°)	(°)	(°)	1	2	3	4	1	2	3	4	1	2	3	4	(K)	(K)
12:10	16	20,6	20,3	26,1	27	27,3	26,6	5,5	6,4	7	6,3	10,1	11	11,3	10,6	7	11,3
12:25	16	20,9	20,9	27,4	27,5	28,1	27,3	6,5	6,6	7,2	6,4	11,4	11,5	12,1	11,3	7,2	12,1
12:40	16	21,3	21,1	27,8	27,7	28,2	27,9	6,5	6,4	7,1	6,8	11,8	11,7	12,2	11,9	7,1	12,2
12:55	16	21,6	21,3	28,2	28,4	29	28,3	6,6	6,8	7,7	7	12,2	12,4	13	12,3	7,7	13
13:10	16	21,9	22	28,6	29,2	29,1	28,6	6,7	7,3	7,1	6,6	12,6	13,2	13,1	12,6	7,3	13,2
13:25	16	22,1	22,3	28,8	29,5	29,8	29,2	6,7	7,4	7,5	6,9	12,8	13,5	13,8	13,2	7,5	13,8
13:40	16	23	23,4	29,1	30,2	30,1	29,5	6,1	7,2	6,7	6,1	13,1	14,2	14,1	13,5	7,2	14,2
13:55	17	24,1	23,7	32,2	31	31,1	31,2	8,1	6,9	7,4	7,5	15,2	14	14,1	14,2	8,1	15,2
14:10	17	24,6	24,1	33	32,3	32,1	32	8,4	7,7	8	7,9	16	15,3	15,1	15	8,4	16
14:25	17	25,2	24,5	33,4	33	33,5	33,1	8,2	7,8	9	8,6	16,4	16	16,5	16,1	9	16,5
14:40	17	25,6	25,6	34,3	33,4	34,8	34,5	8,7	7,8	9,2	8,9	17,3	16,4	17,8	17,5	9,2	17,8
14:55	17	26,3	27,3	35,5	34,4	36,2	35,5	9,2	8,1	8,9	8,2	18,5	17,4	19,2	18,5	8,9	19,2
15:10	18	26,7	27,6	36,7	35,3	37,1	36,1	10	8,6	9,5	8,5	18,7	17,3	19,1	18,1	9,5	19,1
15:25	18	27,7	27,9	37,7	37	38,2	37,2	10	9,3	10,3	9,3	19,7	19	20,2	19,2	10,3	20,2

a. Temperature difference of the hot spot point of the elementary stator magnetic core in relation to the ambient temperature measured during the test and the referred to magnetic flux density of 1T and rated frequency of 50 Hz, according to the given criteria is:

$$\theta = \vartheta_{\max} - \vartheta_a = 38,2 - 18 = 20,2 \text{ K}$$

and it is less than the value $\theta = 25,0 \text{ K}$.

b. The maximum difference between hot spot and cold spot part of the elementary stator magnetic core, measured during the test and referred to magnetic flux density of 1T and a frequency of 50 Hz, according to the given criteria is:

$$\Delta\theta = \vartheta_{\max} - \vartheta_r = 38,2 - 27,9 = 10,3 \text{ K}$$

and is less than the value $\Delta\theta = 15 \text{ K}$.

c. Specific power losses in stator magnetic core referred to magnetic flux density of 1T and a frequency of 50Hz, according to the above-mentioned criteria is 1,97 W / kg and is less than 2,5 W / kg.

d. Stator core test is extended after the expiration of 90 minutes until 15:25 pm, in order to check whether temperatures evenly distributed along the surface of the magnetic core and if there be observed some abnormal phenomena. While not significant differences in terms of heating of stator magnetic core.

6. CONCLUSION AND OPINION

From the analysis of the presented results of the tests and measurements of the synchronous generator stator magnetic, it can be concluded that: stator magnetic core has stood the "stator core test of heating" with excitation winding and meets the adopted criteria in relation to the hot spot temperature of the elementary parts and specific power losses because they are categorized into "normal operation condition."

Regarding the state of the stator magnetic core recommended permanent operation of the synchronous generator until the next scheduled tests.

REFERENCES

- [1] VDE (Verband der Elektrotechnik, Elektronik und Informationstechnik)
- [2] Sutton, J., "EL CID: an easier way to test stator cores", Electrical Review, Vol. 207, No. 1, 1980.
- [3] G.K.Kidley, D.R.Bertenshaw, "A deeper insight into EL CID", Hidropower&Dams, Issue Four, 2005.

- [4] Red Gamblin, Barry Solomon, Manitoba Hydro, “Experience with hidrogenerator core testing and repair”, Iris Rotating Machine Conference, June 2002, San Antonio, TX.

Information about the authors:

Dr. Mihail Digalovski – Associate Professor at the Department of Electrical Machines, Transformers and Apparatuses, Faculty of Electrical Engineering & IT, “Ss. Cyril and Methodius” University, Skopje, Republic of North Macedonia.

Dr. Krste Najdenkoski – Full Professor at the Department of Electrical Machines, Transformers and Apparatuses, Faculty of Electrical Engineering & IT, “Ss. Cyril and Methodius” University, Skopje, Republic of North Macedonia.

Dr. Goran Rafajlovski – Full Professor at the Department of Electrical Machines, Transformers and Apparatuses, Faculty of Electrical Engineering & IT, “Ss. Cyril and Methodius” University, Skopje, Republic of North Macedonia. Professor at School of Technology, SRH University of applied science Berlin, Germany. Senior member of IEEE IAS Society.

Manuscript received on 29 March 2021