

Volume 11  
Issue 1  
July 2022

ISSN - 1857 - 839X

**SJCE**  
SCIENTIFIC  
JOURNAL  
OF CIVIL  
ENGINEERING

**SJCE**  
SCIENTIFIC  
JOURNAL  
OF CIVIL  
ENGINEERING



SS CYRIL AND METHODIUS UNIVERSITY  
FACULTY OF CIVIL ENGINEERING

SS CYRIL AND METHODIUS UNIVERSITY  
FACULTY OF CIVIL ENGINEERING

### FOUNDER AND PUBLISHER

Faculty of Civil Engineering  
Partizanski odredi 24, 1000  
Skopje, N. Macedonia

### PRINT

This Journal is printed in Mar-saz  
DOOEL Skopje

### EDITORIAL OFFICE

Faculty of Civil Engineering  
Partizanski odredi 24, 1000  
Skopje, N. Macedonia  
tel. +389 2 3116 066  
fax. +389 2 3118 834  
prodekan.nauka@gf.ukim.edu.mk

### EDITOR IN CHIEF

Assoc. Prof. PhD **Marijana Lazarevska**  
University "Ss. Cyril and Methodius"  
Faculty of Civil Engineering  
Partizanski odredi 24, 1000  
Skopje, N. Macedonia  
marijana@gf.ukim.edu.mk

### EDITORIAL ADVISORY BOARD

Prof. PhD **Elena Dumova-Jovanoska**  
University "Ss. Cyril and Methodius", Skopje, N. Macedonia

Assoc. Prof. PhD **Zlatko Bogdanovski**  
University "Ss. Cyril and Methodius", Skopje, N. Macedonia

### TECHNICAL EDITORS

MSc **Milica Jovanoska**  
Assistant, University "Ss. Cyril and Methodius", Skopje, N. Macedonia

PhD **Kristina Milkova**  
Assistant, University "Ss. Cyril and Methodius", Skopje, N. Macedonia

MSc **Riste Volcev**  
Assistant, University "Ss. Cyril and Methodius", Skopje, N. Macedonia

**ISSN: 1857-839X**

### EDITORIAL BOARD

**Rita Bento, PhD**  
Instituto Superior Técnico,  
Universidade de Lisboa,  
Department of Civil Engineering,  
Architecture and Georesources,  
Lisbon, Portugal

**Zlatko Bogdanovski, PhD**  
University "Ss. Cyril and Methodius", Faculty of Civil Engineering, Skopje, N. Macedonia

**Heinz Brandl, PhD**  
Vienna University of Technology,  
Institute for Geotechnics, Vienna,  
Austria

**Maosen Cao, PhD**  
Hohai University, Department of Engineering Mechanics, Nanjing, China

**Eleni Chatzi, PhD**  
ETH Zurich, Chair of Structural Mechanics & Monitoring, Zurich, Switzerland

**Tina Dasic, PhD**  
University of Belgrade, Faculty of Civil Engineering, Belgrade, R. Serbia

**Ljupco Dimitrievski, PhD**  
University "Ss. Cyril and Methodius", Faculty of Civil Engineering, Skopje, N. Macedonia

**Katerina Donevska, PhD**  
University "Ss. Cyril and Methodius", Faculty of Civil Engineering, Skopje, N. Macedonia

**Elena Dumova-Jovanoska, PhD**  
University "Ss. Cyril and Methodius", Faculty of Civil

Engineering, Skopje, N. Macedonia

**Michael Havbro Faber, PhD**  
Aalborg University, Department of Civil Engineering, Aalborg, Denmark

**Massimo Fragiaco, PhD**  
University of L'Aquila, Department of Civil, Construction-Architectural & Environmental Engineering, L'Aquila, Italy

**Tomas Hanak, PhD**  
Brno University of Technology, Faculty of Civil Engineering, Brno, Czech Republic

**Nenad Ivanisevic, PhD**  
University of Belgrade, Faculty of Civil Engineering, Belgrade, R. Serbia

**Milos Knezevic, PhD**  
University of Montenegro, Faculty of Civil Engineering, Podgorica, Montenegro

**Andrej Kryzanowski, PhD**  
University of Ljubljana, Faculty of Civil and Geodetic Engineering, Ljubljana, Slovenia

**Stjepan Lakusic, PhD**  
University of Zagreb, Faculty of Civil Engineering, Zagreb, Croatia

**Marijana Lazarevska, PhD**  
University "Ss. Cyril and Methodius", Faculty of Civil Engineering, Skopje, N. Macedonia

**Peter Mark, PhD**  
Ruhr University, Faculty of Civil and Environmental Engineering, Bochum, Germany

**Marc Morell**  
Institute des Sciences de l'Ingénieur de Montpellier, France

## Impressum

---

### **Vlastimir Radonjanin, PhD**

University of Novi Sad, Faculty of Technical Sciences, Novi Sad, R. Serbia

### **Marina Rakocevic, PhD**

University of Montenegro, Faculty of Civil Engineering, Podgorica, Montenegro

### **Resat Ulusay, PhD**

Hacettepe University, Faculty of Engineering, Ankara, Turkey

### **Joost C. Walraven, PhD**

Delft University of Technology, Department of Civil Engineering, Delft, Netherlands

### **Zlatko Zafirovski, PhD**

University "Ss. Cyril and Methodius", Faculty of Civil Engineering, Skopje, N. Macedonia

### **Ales Znidaric, PhD**

ZAG – Slovenian National Building and Civil Engineering Institute, Ljubljana, Slovenia

### **COVER DESIGN:**

Prof. PhD **Mitko Hadzi Pulja**  
Mr. Arh **Darko Draganovski**  
Faculty of Architecture  
University "Ss. Cyril and Methodius", Skopje, N. Macedonia

### **ORDERING INFO**

**SJCE** is published bi-annually.  
All articles published in the journal have been reviewed.  
Edition: 100 copies

### **SUBSCRIPTIONS**

Price of a single copy:  
for Macedonia (500 den);  
for abroad (10 EUR + shipping cost).

### **BANKING DETAILS (NORTH MACEDONIA)**

Narodna banka na RNM  
Account number:  
160010421978815  
Prihodno konto 723219,  
Programa 41

### **BANKING DETAILS (INTERNATIONAL)**

Correspond bank details:  
Deutsche Bundesbank Zentrale  
Address: Wilhelm Epstein Strasse  
14 Frankfurt am Main, Germany  
SWIFT BIC: MARK DE FF  
Bank details:  
National Bank of the RNM  
Address: Kompleks banki bb 1000  
Skopje North Macedonia  
SWIFT BIC:NBRM MK 2X  
IBAN: MK 07 1007 0100 0036 254  
Name: Gradezen fakultet Skopje

V. Gacevski, V. Zileska Pancovska, M. Lazarevska ASSESSMENT OF RISKS IN A ROAD TUNNEL CONSTRUCTION USING TREE ANALYSIS	7
T. Gegovski, Z. Bogdanovski, F. Kasapovski A REVIEW OF INSAR TECHNOLOGY FOR DETERMINATION OF SURFACE DEFORMATION	13
D. Memedi, D. Popovski, M. Partikov, A. Nasufi ANALYTICAL MODEL OF NON-SWAY STEEL FRAME WITH SEMI-RIGID CONNECTIONS	21
V. Mickovski, G. Iannace, M. Jovanoska-Mitrevska, T. Samardzioska REBONDED POLYURETHANE FLEXIBLE FOAM AS SOUND ABSORBING MATERIAL	27
A. Nasufi, D. Popovski, M. Partikov, D. Memedi OPTIMIZATION OF STEEL FRAMES USING SEMI-RIGID CONNECTIONS	35
M. Naumovski, M. Lazarevska, D. Dimkovski COMFORT, AS AN ASPECT OF LIFE CYCLE ASSESSMENT (LCA) ANALYSIS TOWARD SUSTAINABLE BUILDINGS	41
I. Nedevska, Z. Zafirovski, M. Lazarevska, R. Ristov, V. Gacevski TRACK GEOMETRY DEGRADATION AND MAINTENANCE OF THE RAILWAYS	55
H. Pasternak, N. Živaljević-Luxor THE COLOSSUS OF PRORA – BUILDING HISTORY AND NEW BEGINNING	61

**Ditar Memedi**

MSc, Assistant  
South East European University  
Faculty of Contemporary Sciences and  
Technologies Tetovo, North Macedonia  
ditarm2@gmail.com

**Denis Popovski**

PhD, Associate Professor  
Ss. Cyril and Methodius University  
Faculty of Civil Engineering – Skopje  
popovski@gf.ukim.edu.mk

**Mile Partikov**

PhD, Assistant Professor  
Ss. Cyril and Methodius University  
Faculty of Civil Engineering – Skopje  
partikov@gf.ukim.edu.mk

**Albnor Nasufi**

MSc, Civ. Eng.  
North Macedonia  
nolinasufi@live.com

## **ANALYTICAL MODEL OF NON-SWAY STEEL FRAME WITH SEMI-RIGID CONNECTIONS**

The distribution of moments in a steel frame is directly correlated, beside other parameters, by the rigidity of the connection between the constituent elements. Depending on the type of beam-column connection, i.e. depending on its initial rotational stiffness, a diagram of internal static quantities is also generated. In design practice, the traditional way of treating a beam-column connection is carried out by assuming one (or their mutual combination) of the following ideal cases:

1. Absolute rigid connection
2. Absolute pinned connection

This of course, misinterprets the actual behavior of the structure and contributes to unnecessary increased material consumption

The real rigidity of a connection is always between these two extremes cases. Eurocode 3, Part 1-8 provides rules and procedures for quantifying the initial rotational stiffness of a bare steel connection, but does not specify how to determine the moment in the connection joint from the influence of given external loads.

The purpose of this paper is to describe the distribution of moments in a non-sway steel frame with semi-rigid connections under the influence of a uniformly distributed vertical loads and to answer the following question:

*Is it more convenient to analyze the beam as an isolated element with semi-rigid connections at the ends or is it necessary to include the rigidity of the vertical elements (columns)?*

This goal has been achieved by proposing a two-parameter analytical model that includes both the rigidity of the columns and the rotational rigidity of end beam connections, all together included in one model. The proposed model is compared to the Liu and Chen model [3] which gives the dependence between the external load and the negative moment in the semi-rigid connection, taking into account only the initial rigidity of the beam-column connection.

According to this model for determining the distribution of moments, the rigidity of the vertical construction – columns is neglected. This way of neglecting the columns in analysis

of a steel frame is also adopted in Eurocode 3, Part 1-8.

This of course contributes to the slight overestimation of the negative moment in the beam-column relationship. Determination of the moment in the sagging and hogging region (connection node) from a given external uniformly distributed vertical load is directly dependent on the rotational rigidity of the connection (secant stiffness,  $S_j$ ) and the rigidity of the vertical structure ( $k_c$ ).

**Keywords:** semi-rigid connections, beam-column connection, rotational stiffness, column stiffness, steel frames.

### 1. PROPOSED TWO-PARAMETER MODEL

The construction of the model starts with the consideration of a bare steel frame with span  $L_b$ . The height of floor 1 and floor 2 are  $h_1$  and  $h_2$  respectively (Figure (1)).

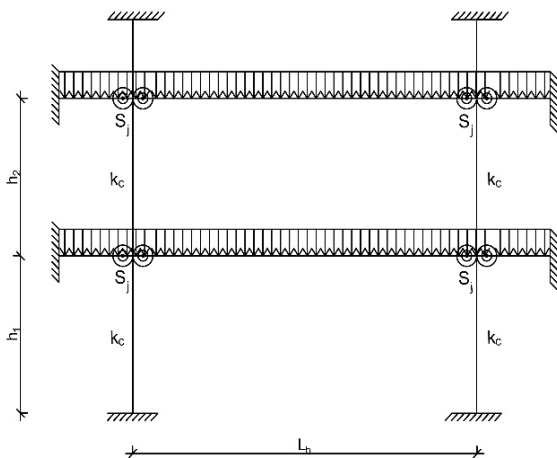

Figure 1. Non-sway bare steel frame with semi-rigid connections

The stiffness of the column beam connection is denoted by  $S_{j,ini}$ , while the stiffness resulting from the columns is denoted by  $k_c$ . To explain the mechanism of transfer of the moment from the beam to the beam-column connection, including column rigidity, an isolated beam is considered as an integral part of the frame, shown in Figure (2).

The correlation between the rigidity of the columns and the rigidity of the beam-column

connection is taken as an integral part in the node itself, it is shown in Figure 2 a). The total stiffness that comes from  $k_c$  and  $S_j$  is denoted by  $k$  and is determined by the equation([4]):

$$\frac{1}{k} = \frac{1}{k_c} + \frac{1}{S_j} \quad (1)$$

Or, equivalently:

$$k = \frac{k_c S_j}{k_c + S_j} \quad (2)$$

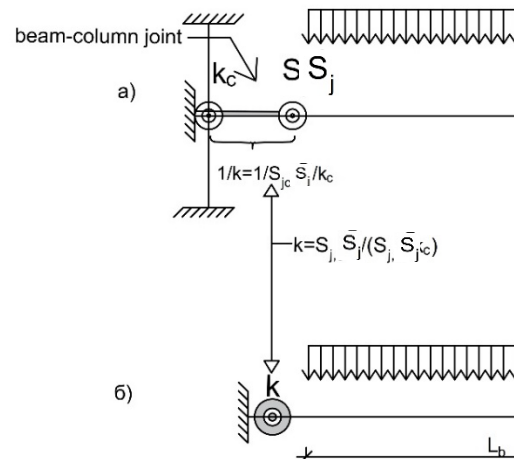

Figure 2. a) Effect of column on beam-column connection b) combining column rigidity  $k_c$  and connection stiffness

The parameter  $k$  is the parameter "S<sub>j</sub>" for the isolated beam, if it is treated according to the philosophy adopted in Eurocode 3, Part 1-8. In addition, the mechanism of transfer of bending moments from the beam to the connection node is shown, with taking into account the above functional parameters. The bending moment at the connection node is related to the relative rotation between the beam-column. The problem is solved in stages:

#### 1.1 ROTATION - STAGE I

In the first stage, the rotation of a simple supporting beam is determined depending on the intensity of the vertical external load according to the expression:

$$\theta_0 = \frac{qL_b^3}{24EI_b} \quad (3)$$

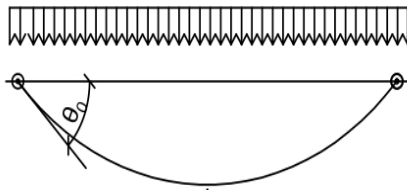

Figure 3. Positive rotation of simply supported beam

### 1.2 ROTATION - STAGE II

In the second phase, two sub-phases are considered:

- Negative end beam rotation with semi-rigid connection ( $\theta_{sr}$ )

Depending on the external uniformly distributed vertical load and the unknown amount of bending moment ( $M_{ed}$ -which is to be determined by this procedure) that appears in the beam-column connection, the "negative" end beam rotation by including these effects is expressed by:

$$\theta_{sr} = \frac{M_{ed}}{2EI_b} \quad (4)$$

- Negative beam rotation due to the rigidity of the column ( $k_c$ )

The relationship between the Negative rotation, the unknown moment in the node ( $M_{ed}$ ) of the connection and the rigidity of the vertical structure that occurs due to the rigid effects of the column is determined by the following relation:

$$\theta_{kc} = \frac{M_{ed}}{k_c} \quad (5)$$

where  $k_c$  is calculated by([5]):

$$k_c = \frac{\alpha_1 E_s I_{c1}}{h_1} + \frac{\alpha_2 E_s I_{c2}}{h_2} \quad (6)$$

- $h_1$  –story height for level 1,
- $h_2$  –story height for level 2 и
- the modulus of elasticity of the columns in the corresponding positions. The coefficient  $\alpha_1$  for columns fixed in the base is 4. If the columns are pinned to the base, then the value of the coefficient is  $\alpha_1 = 3$  while the coefficient  $\alpha_2$ , would always have the value  $\alpha_2 = 4$ .

Together with the above-mentioned, by adopting the principle of superposition of influences, these two sub-mechanisms are combined as shown in the following sketch:

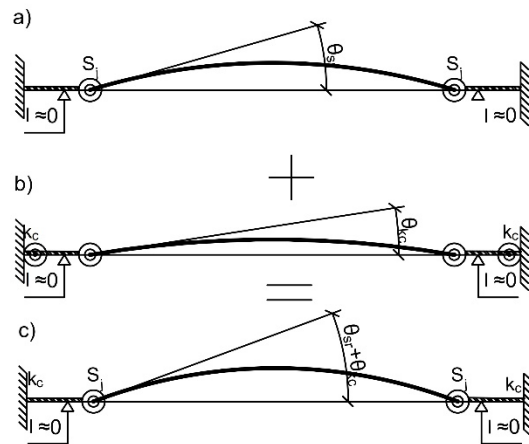

Figure 4. a) Negative rotation due to beam-column stiffness b) Negative rotation due to column rigidity c) Overall negative rotation from last two effects

The sum of the positive rotation of simply supported beam and the last two „negative” rotations (based on Figure 4c) is:

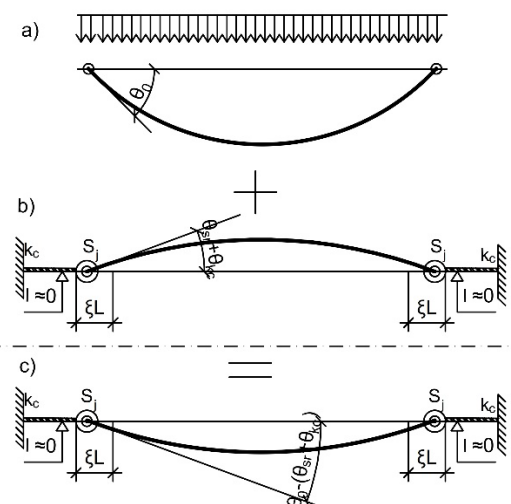

Figure 5. a) Positive rotation due to stage I b) Negative rotation due to stage II c) Overall positive rotation due to combined effects

The last one (Figure 5c), mathematically is represented by:

$$\begin{aligned} \theta_{S_j} &= \theta_0 - (\theta_{sr} + \theta_{kc}) \quad (7) \\ &= \frac{ql^3}{24EI_b} - \left( \frac{M_{ed}}{2EI_b} + \frac{M_{ed}}{k_c} \right) \end{aligned}$$

Where  $\theta_0$ ,  $\theta_{sr}$  and  $\theta_{kc}$  denote the rotation of a simple beam, the negative rotation due to the semi-rigid effects at the end beam and the negative rotation due to the rigidity of the columns, respectively.

The correlation between the external load moment ( $M_{ed}$ ) and the corresponding secant

stiffness  $S_j$  is given by the well-known expression:

$$\theta_{S_j} = \frac{M_{ed}}{S_j} \quad (8)$$

By equalizing expressions (7) and (8), the hogging moment of the external load at the column-beam connection can be represented as follow:

$$\frac{M_{ed}}{S_j} = \frac{ql^3}{24EI_b} - \left( \frac{M_{ed}}{2EI_b} + \frac{M_{ed}}{k_c} \right) \quad (9)$$

Expressing  $M_{ed}$  from (9) gives:

$$M_{ed} = \frac{ql_b^3}{24EI_b} \frac{1}{\left( \frac{1}{S_{j,c}} + \frac{1}{k_c} + \frac{L_b}{2EI_b} \right)} \quad (10)$$

Equation (10) can be transformed into the following form:

$$M_{ed} = \frac{\frac{ql_b^3}{24EI_b}}{\frac{L_b}{EI_b} \left( \frac{EI_b}{S_{j,c}L_b} + \frac{EI_b}{k_cL_b} + \frac{1}{2} \right)} \quad (11)$$

If  $\frac{S_{j,c}L_b}{EI_b}$  and  $\frac{k_cL_b}{EI_b}$  are denoted by  $R_1$  and  $R_2$ , respectively, then the last expression would take the final form:

$$M_{ed} = \frac{2R_1R_2}{3(2R_1+2R_2+R_1R_2)} \cdot M_{sag}^0 \quad (12)$$

The proposed two parameter model (12) incorporates the parameters  $R_1$  and  $R_2$  and the sagging bending moment  $M_{sag}^0$  if the beam is considered as a simply supported beam. That is, the moment of the external load in the connection node is given as a functional dependence on the following parameters:

$$M_{ed} = M_{ed}(M_{sag}, S_j, k_c) \quad (13)$$

The coefficient  $\frac{2R_1R_2}{3(2R_1+2R_2+R_1R_2)}$  is always a number less than 1. In other words, this quotient is a reduction of the sagging moments of a simply supported beam and the same reduction is transmitted from region of positive moment to the node of the semi-rigid beam-column connection.

## 2. DESCRIPTION OF ONE-PARAMETER MODEL ACORDING TO LIU AND CHEN

As a comparison, if we do not take into account the participation of the vertical construction then a change in the law of moments instead of a two-parameter function (12) would be described using a graph of a function of one main variable ( $S_j$ ). That's only with one parameter i.e. the parameter  $R_1$ . The next paragraph describes the philosophy of this approach.

The total end beam rotation is assumed to be the sum of the rotation when the beam is considered to be simply supported by a uniformly distributed load and the "negative" rotation when the beam is exposed to a negative moment due to the semi-rigid effect that causes the beam to "overhang".

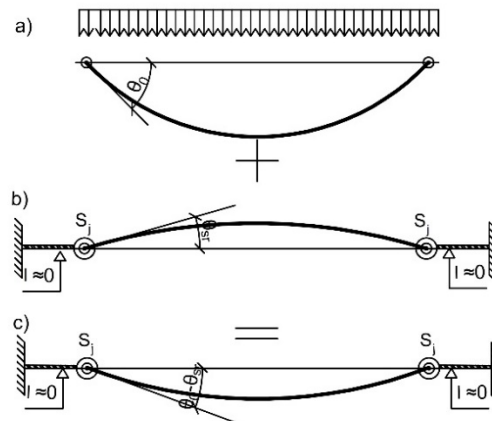

Figure 6. a) Positive rotation due to stage I b) Negative rotation due to beam-column rotational stiffness c) Overall positive rotation due to combined effects

Where:

- $\theta_0$ : Rotation of a simply supporting beam by the action of an uniformly distributed vertical load
- $\theta_{sr}$ : Negative rotation due to the effect of a semi-rigid connections
- $S_j$ : Secant rigidity of bare steel semi-rigid connection

In this model, it is evident that the columns do not participate in the distribution of moments. As in previous model, the superposition principle is assumed so the total rotation of the end beam node can be defined as:

$$\theta_j = \theta_0 - \theta_{sr} \quad (14)$$

$$\theta_0 = \frac{ql_b^3}{24EI_b} \quad (15)$$

$$\theta_{sr} = \frac{ML_b}{2EI_b} \quad (16)$$

By substituting equations (16) and (15) in equation (14) we get:

$$\theta_j = \frac{qL_b^3}{24EI_b} - \frac{M_{ed}L_b}{2EI_b} \quad (17)$$

By equalizing equations (17) and (8), the moment in the semi-rigid connection node is determined according to the relation:

$$M_{ed} = \frac{2R_1}{3(R_1+2)} M_{sag}^0 \quad (18)$$

Where:

- $R_1$ : coefficient of rotational stiffness which is  $R_1 = \frac{S_{j,c}L_b}{EI_b}$ .
- $M_{sag}^0$ : The moment in sagging region when the beam is treated as simply supported.

### 3. COMPRAISON OF THE PROPOSED MODEL WITH THE ONE PARAMETRIC MODEL

To have a better understanding on differences between the proposed model and the standard one parametric model [3], the following example is considered:

A bare steel frame with two stories under the influence of uniformly distributed vertical load of  $g_{ed} = 12.5 \text{ kNm}$  is considered. The columns are selected as HEB160 with height of  $h_1 = 4\text{m}$  and  $h_2 = 3\text{m}$ . The beam is selected as IPE240 with span  $L_b = 8\text{m}$ .

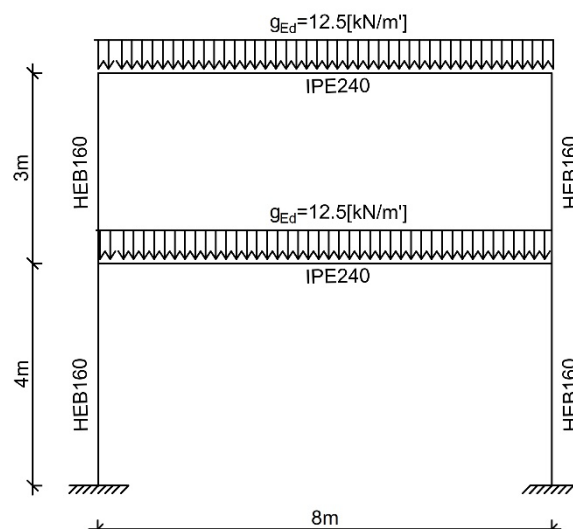

Figure 7. a) Positive rotation due to stage I b) Negative rotation due to beam-column rotational stiffness c) Overall positive rotation due to combined effects

The initial rotational stiffness and the secant stiffness of the beam-column connection calculated in [5] are: 8816 kNm/rad and 4408 kNm/rad, respectively. With the implementation of the proposed method, the moment in the connection node ( $M_{hog}$ ) as well as sagging moment ( $M_{sag}$ ) for the first story are determined by calculating all the necessary parameters. The results for the proposed model are shown in the table below.

Table 1. Calculation according to the proposed model

Parameter	Calculated parameters
$S_{j,ini}$	8816 kNm/rad
$S_j$	4408 kNm/rad
$R_1$	4.31
$k_c$	12210.8 kNm
$R_2$	11.92
$\frac{2R_1R_2}{3(2R_1 + 2R_2 + R_1R_2)}$	0.4
$M_{sag}^0$	100 kNm
$M_{hog}$	40 kNm
$M_{sag}$	60 kNm

From the shown table calculations, it is noticed that the positive bending moment,  $M_{sag}$ , is 60 kNm

In the following table, the calculation of the positive moments,  $M_{sag}$ , for the same example

was carried out, but with the implementation of the one-parameter model.

Table 2. Calculation according to the one-parameter model

Parameter	Calculation of parameters
$S_{j,ini}$	8816 kNm/rad
$S_j$	4408 kNm/rad
$R_1$	4.31
$\frac{2R_1}{3(R_1 + 2)}$	0.46
$M_{sag}^0$	100 kNm
$M_{hog}$	46 kNm
$M_{sag}$	54kNm

From the performed analysis, it is noticed that, for the same frame and the same level of loads, the positive moment for the first story is 54 kNm.

A comparison of the obtained results is described in the following sketch:

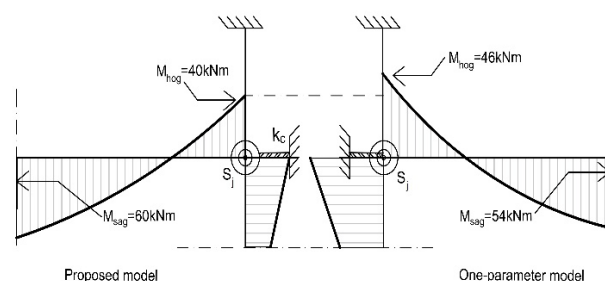

Figure 8. Hogging and sagging moments calculated by proposed model and their comparison with moments calculated by one-parameter model.

## 4. CONCLUSION

This paper presents a two-parameter analytical model for determining the negative moment in a semi-rigid bare steel, beam to column connection.

In this model, in addition to the secant rigidity of the beam-column connection, the rigidity of the vertical construction is considered through the parameter  $k_c$ . The purpose behind the introduction of this parameter was to assess whether the neglect of the column rigidity has a favorable or unfavorable effect on the distribution of moments in a bare steel frame.

Next, a one parameter model based on Liu and Chen([3]) is presented and their mechanism of transferring the bending moment in a bare steel frame is compared.

The reason for this comparison (with a one-parameter model) is precisely due to the fact that the philosophy of dealing with this issue in Eurocode 3 is based on this one-parameter model.

From the conducted analysis, with the two-parameter model, for the same frame and the same level of loads, the sagging moment is approximately 10% higher compared to the one-parameter model.

As a final conclusion can be drawn that, analysing a beam as an isolated beam with semi-rigid connections and excluding column rigidity implies underestimating sagging moment and overestimating the hogging moments.

## REFERENCES

- [1] EN 1991-1-1: Eurocode 3: Design of steel structures – Part 1-1: General rules and rules for buildings, CEN 2005.
- [2] EN 1991-1-8: Eurocode 3: Design of steel structures – Part 1-8: Design of joints, CEN 2005.
- [3] Chen, W. F. and Lui, E. M. „Stability design of steel frames“ CRC Press, 1991. Eurocode - Basis of structural design
- [4] Faella, C., Piluso, V., and Rizzano, G., „Structural steel semi-rigid connections— Theory, design and software“, CRC Press, Boca Raton, FL, 2000.
- [5] Y.L. Wong, T. Yu, S.L. Chan. „A simplified analytical method for unbraced composite frames with semi-rigid connections“, Journal of Constructional Steel Research, 63 (2007)
- [6] М. Дитар: „Анализа на спрегнати рамки со полукрути спрегнати врски“(Master Thesis, 2022)