

ENERGY EFFICIENCY OF COMBINED COMPRESSOR-EJECTOR VAPOR COMPRESSION SYSTEMS APPLIED IN INDUSTRIAL CONCENTRATORS

by

**Aleksandar A. GJERASIMOVSKI^a, Natasha A GJERASIMOVSKA^b,
and Vasko N. ŠAREVSKI^a**

^aFaculty of Mechanical Engineering,
Ss. Cyril and Methodius University, Skopje, Republic of North Macedonia
^bESM – Power Plants of Macedonia, Skopje, Republic of North Macedonia

Original scientific paper
<https://doi.org/10.2298/TSCI240613257G>

Investigations of the energy characteristics of thermocompression systems applied in industrial concentrators are presented in this paper. A significant increase of the energy efficiency in comparison with traditional industrial concentrators is achieved with the implementation of turbocompressor and/or ejector thermocompression. Single stage centrifugal compressors with water (R718) as a refrigerant are especially suitable for application in concentrators for production of fruit or grape concentrates because of the relatively small temperature difference between condensation and evaporation temperatures ($T_c - T_e$). The heat pump cycle in the ejectors is realized with thermocompression of one part of the waste water vapor in the solution, which together with the primary steam from the boiler, or other heat generator, is used as a motive steam for the process of concentration. Several solutions of highly efficient single stage and multistage concentrator systems with turbocompressor and/or ejector thermocompression are proposed. The process of boiling - evaporation of the water from the treated solution in the concentrator is realized at low temperatures, under deep vacuum conditions, which is a guarantee for a high product quality. Due to the low costs of conventional fuels used in the processes of production of concentrate, the products made with these procedures are relatively low-priced, which makes them competitive on the market. A solution of a polygeneration system for production of electricity and thermal energy (steam and hot water) for the needs of technological processes in industrial concentration plants is presented.

Key words: *industrial concentrators, thermocompression, energy efficiency, polygeneration, fruit concentrate*

Introduction

Thermocompression systems and their optimal implementation in high energy efficiency technologies represent a significant component in the new concept of sustainable development in the energy sector and in the sector of the process industry that is presented in [1]. This new concept offers an unique approach that can contribute towards the energy transition.

^aCorresponding author, e-mail: aleksandar.gerasimovski@mf.edu.mk

The new concept relies on the utilization of original setups of gas engine (GEN) polygeneration systems. Different setups of these polygeneration systems are described where the waste heat from the engine is optimally recovered for heating and cooling energy generation in different configurations of industrial systems or building HVAC&R systems [2, 3].

In industrial systems energy consumption during the production of a certain product has a significant role in forming the price of the product which imposes the need to find solutions with high energy efficiency. Because of technical and economic reasons, and especially due to the environmental problems related to global warming, increasing energy efficiency has become the main topic and subject of numerous scientific research and development activities in the field of thermal machines, devices, plants, and systems. In that context, the research of thermodynamic and flow processes in thermocompression systems and the optimal implementation in thermal technologies with high energy efficiency represents a modern topic of remarkable research interest.

Industrial concentrators are widely used in technological processes from the process industry (chemical and pharmaceutical industry, beer industry, food, dairy, meat and canning industry, fruit, tomato, and grape concentrate production industries, *etc.*) [2]. High power consumption is a general characteristic of industrial concentrators. A reduction in energy consumption can be achieved by using multistage concentrators or by using high temperature heat pumps with thermocompression (ejector and/or turbocompressor), where waste heat (water vapor) from the concentrator plant is raised to a higher pressure and temperature by thermocompression and is used as a driving energy for the process. The process of evaporation – boiling of the concentrating solution in the proposed systems takes place under conditions of deep vacuum, which enables low temperature operation of the concentrator and low temperature treatment of the product. This way, a highquality concentrate is produced, with retained properties (aroma, vitamins, natural color) of the material being treated.

Vapor ejector cycle is largely used in refrigeration technology [3]. Solar energy driven ejector cycle in a hybrid, mechanical compression enhanced ejector cycle is suggested in [4, 5]. The ejector cycle has low operating cost because of the use of cheap thermal energy that is available. The idea of water turbo compressor refrigeration systems started at the end of 1980's and 1990's and continued in the 21st century [6, 7]. The combination of water ejector and turbocompressor cycle in refrigeration systems but also in industrial concentrators is an advanced solution that results in high energy efficiency [8]. Thermal characteristics of combined compressor – ejector refrigeration/heat pump systems applied in heating, ventilation, air conditioning and refrigeration (HVAC&R) of buildings are investigated in [9].

The purpose of this paper is to present an investigation of industrial concentrators and to emphasize the significant increase in their energy efficiency with application of systems with turbocompressor and/or ejector thermocompression. Both technologies for thermal vapor compression are separately analyzed at the beginning. High values of the thermotransformation coefficient (efficiency coefficient) can be achieved with thermocompression of the waste evaporated water that is usually dumped in the environment in conventional industrial concentrators. This process of utilizing the latent heat of condensation of the waste evaporated liquid by mechanical vapor compression is much more investigated for desalination and purposes and for distillation processes for concentration of chemical solutions [10]. The use of thermal or ejector vapor compression is also primarily used in desalination plants. It is also very rare to find a combined compression systems, mechanical and thermal, that operates in vacuum conditions in the existing investigations. This paper provides several solutions of highly efficient single stage and multistage vacuum concentrator systems with combination of turbocompressor and

ejector thermocompression. The energy balances are provided for these solutions. A combined polygeneration system for production of electricity and thermal energy (steam and hot water) for the needs of technological processes in industrial concentration plants is presented. The combination of the two types of thermal vapor compression technologies in the presented systems is done in an original manner.

Concentrators with turbocompressor thermocompression

The main part of the turbocompressor thermocompression systems is the centrifugal compressor. Analysis was performed with water (R718) as an operating fluid. As a result of the intensive research and development activities in the field of turbocompressors, supported by achievements in thermodynamics and fluids mechanics, improvement of strength characteristics of materials, application of frequency regulators, fluid magnetic bearings, *etc.*, high speed centrifugal compressors with high energy efficiency are produced [11].

The technical and environmental advantages of water as an operating fluid and its thermodynamic properties are well known. Centrifugal compressors, with water as an operating fluid, are particularly suitable for application in thermocompression systems in concentrator plants.

The use of R718 centrifugal compressors in thermocompression systems for industrial concentrators has certain peculiarities. The high normal evaporation temperature of water causes a high required compression ratio, because of the large difference between the condensation and evaporation temperatures ($T_c - T_e$), to achieve the required temperature lift. Since the specific volumetric capacity of water evaporation is small, the volume flows and consequently the dimensions of the compressor are large. Due to the small molecular mass of water, R718 centrifugal compressors when working with moderate peripheral speeds of the impeller (350-400 m/s) achieve a relatively low compression ratio. Therefore, for higher compression ratios the number of revolutions of the compressor impeller needs to be appropriately higher. The advancement in the field of materials and the improvement of their strength properties have enabled construction of compressor impellers with relatively small dimensions that work with extremely high rotational speed (up to 250000 min^{-1}) and peripheral speeds of up to 700 m/s, thus enabling the achievement of a high compression ratio. Design and control of ultra high speed turbocompressor with small dimensions and extremely high rotational speed is performed in [12]

Single stage R718 centrifugal compressors designed for thermocompressor systems can find a wide range of applications in industrial concentrators. Evaporation temperatures (compressor inlet) are relatively high and given the relatively small temperature difference between the temperature of condensation (compressor outlet) and evaporation ($\Delta T_w = T_c - T_e$), the appropriate compression ratio can be achieved with a single stage centrifugal compressor, fig. 1.

The large value of the water isentropic exponent ($k = c_p/c_v$) causes high discharge temperatures from the compressor. As a result of this, part of the solution is exposed to high temperature which can be a problem for the production of high-quality concentrate.

Scheme of a turbocompressor thermocompression concentrator is given in fig. 2. In the main heat exchanger evaporator/condenser, the water contained in the solution evaporates. Thermocompression is realized by compressing the water vapor contained in the solution from evaporation pressure, p_e , and evaporation temperature, T_e , to a higher pressure, p_c , corresponding to the condensation temperature, T_c , in order to obtain an effective temperature difference $\Delta T = T_c - T_e$. The temperature difference, ΔT , has a very large influence on the power consumption for the mechanical compression, as well as on the optimization of the heat exchange surface of the main evaporator/condenser heat exchanger. Initial steam from a boiler

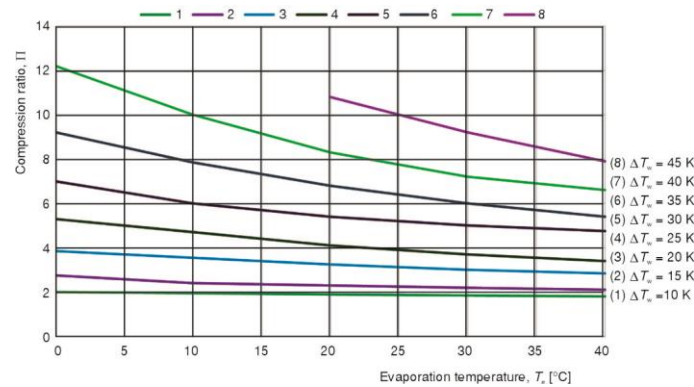

Figure 1 Dependence of R718 pressure ratio (Π) on evaporating temperature, T_e , for different values of the temperature lift, ΔT_w

or other heat generator (waste heat) can be used to start the concentrating process. Even without initial boiler steam, a stationary concentrating process would be established in a relatively short time.

Several solutions of multistage concentrator plants with turbocompressor thermotransformation are shown in figs. 3-5. A general characteristic of such plants is high energy efficiency. Figure 3 shows a multistage concentrator with three turbocompressor units with a low compression ratio. The scheme of a concentrator with one high pressure turbocompressor is shown in fig. 4.

In fig. 5 a concentrator with steam turbine (turboexpander) driven turbocompressor is presented. The first stage of the concentrator is with turbocompressor thermocompression. The steam exiting the turbine is used in the second and lower stages of the concentrator.

The main parameter to express the efficiency of the concentrating system with turbocompressor thermocompression is the thermotransformation coefficient:

$$\Psi = \text{COP} = \frac{Q_c}{P} = \frac{Q_e + P}{P} \quad (1)$$

The thermotransformation coefficient is the ratio of the obtained heat, Q_c , and the power consumption of the turbocompressor, P , that is used to thermotransform the heat of the water vapor contained in the solution, Q_e , from temperature, T_e , to temperature, T_c .

The values of the thermotransformation coefficient are relatively high and they mainly depend on the energy efficiency of the turbocompressor and the operation conditions of the concentrating process:

- $\Psi = \text{COP} = (27 - 31)$ for temperature lift $\Delta T = 10$ K
- $\Psi = \text{COP} = (13 - 15)$ for temperature lift $\Delta T = 20$ K
- $\Psi = \text{COP} = (5.5 - 6.5)$ for temperature lift $\Delta T = 50$ K
- $\Psi = \text{COP} = (2.5 - 3.5)$ for temperature lift $\Delta T = 100$ K

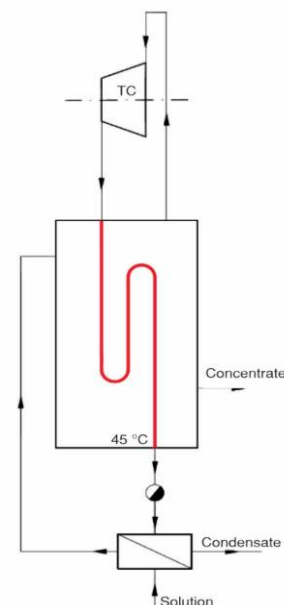

Figure 2. Single stage turbocompressor thermocompression concentrator

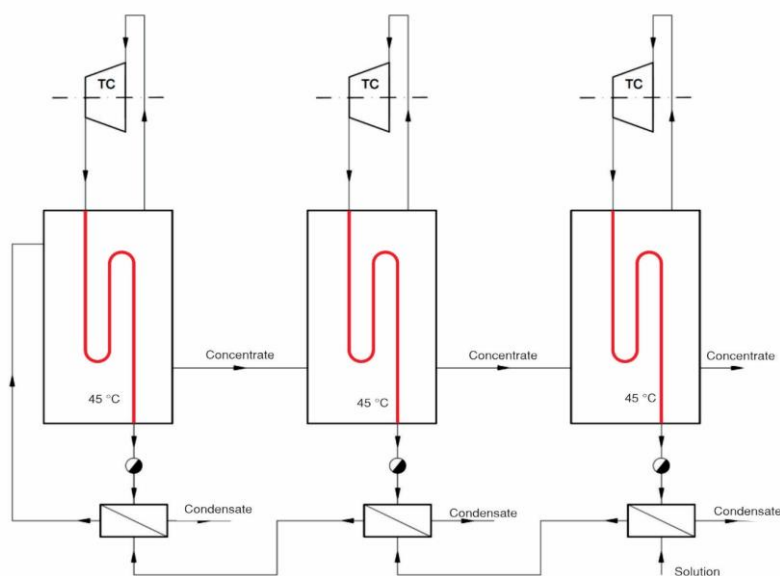

Figure 3. Multistage concentrator system with three turbocompressor units

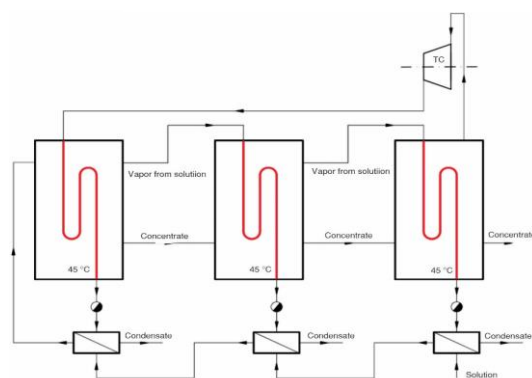

Figure 4. Multistage concentrator system with one high pressure turbocompressor unit

The high temperature on the discharge of the centrifugal compressor in the first section of the main heat exchanger evaporator/condenser in the multistage concentrator system with one high pressure turbocompressor unit, fig. 4, can have a significantly negative impact on the quality of the concentrate (occurrence of caramelization, change of natural color, and loss of nutrituous characteristics – vitamins, minerals, aroma, *etc.*). This is especially important for concentrates from grapes, fruits, tomatoes, *etc.* Under conditions of high temperatures, the possibilities for accumulation of deposits on

the heat exchange surfaces are more pronounced. These problems can be solved by cooling the superheated steam by injecting water in the compressor discharge or by installing a separate heat exchanger – subcooler for the superheated steam on the compressor discharge.

Concentrators with ejector thermocompression

In ejector thermocompression concentrators, thermocompression is achieved with steam from a steam boiler or another heat generator. The use of thermal energy can be a significant advantage over mechanical thermocompression, especially if waste heat is used to produce the steam. In the ejector thermocompression systems the ejector acts as a compressor in traditional vapor compression heat pump cycles [13].

transferred to the environment. To achieve and maintain a vacuum in the concentrator, it is necessary to install a vacuum pump which can be ejector driven.

Scheme of a multistage concentrator with ejector thermocompression is given in fig. 7. The selection of the optimal scheme and optimization of the concentrator plant is carried out according to techno-economic criteria.

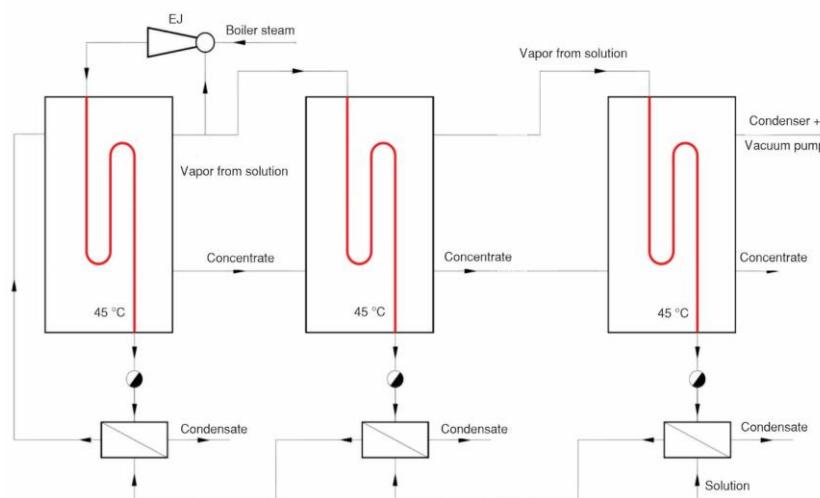

Figure 7. Multistage concentrator system with ejector thermocompression

In order to achieve high-quality of the produced concentrate, it is necessary to treat the solution at a low temperature for concentration – evaporation, in deep vacuum conditions. This applies especially to the production of grape, fruit, tomato concentrates, *etc.* For this reason, a single stage concentrator with mechanical or ejector thermocompression is preferably used instead of multistage concentrator system with one high pressure turbocompressor or ejector unit.

The boiling (evaporation) temperature of the solution, T_{er} , is above the boiling temperature of water, T_e , for a corresponding pressure, p_e , *i.e.* $\Delta T_r = T_{er} - T_e$. The ejector achieves a compression ratio $\Pi = p_c/p_e$ that corresponds to a temperature lift of $\Delta T = T_c - T_e$ for pure water but has to be enough to obtain an optimal (effective) temperature difference in the main heat exchanger, $\Delta T_e = T_c - T_{er}$, between the condensation temperature, T_c , of the turbo compressor/ejector vapor and the boiling temperature of the solution, T_{er} . Condensation temperature, in addition to the impact on the energy efficiency in the thermocompression process, can be limited due to the impact on the quality of the concentrate, especially in the production of grape and fruit concentrate. Higher temperatures can also have a negative impact on the heat exchange processes, due to the accumulation of deposits on the heat exchange surfaces.

The energy efficiency of the ejector thermocompressor heat pumps is evaluated by the thermotransformation coefficient, Ψ_{ej} (COP_e), which represents the ratio between the obtained (thermotransformed) heat Q_c and the consumed heat Q_p for the production of primary boiler steam M_p , with which a part of the waste heat (waste steam M'_e) in the ejector is transformed from pressure, p_e , and temperature, T_e , to higher pressure, p_c , and temperature, T_c :

$$\Psi_{ej} = COP_{ej} = \frac{Q_c}{Q_p} = \frac{M_c}{M_p} \quad (2)$$

The resulting product steam, which condenses by performing the thermal concentration process, amounts to: $M_c = M_e' + M_p$. The second part of the evaporated water from the solution $M_e' = M_e - M_e$ condenses in a water-cooled condenser.

The performance of the ejector highly depends on the operating conditions of the concentrator. The compression ratio, Π , and the temperature lift $\Delta T_{ej} = T_c - T_e$ achieved by the ejector thermocompressor depend on the entrainment ration $\omega = m_{sec}/m_{pr} = M_e'/M_p$. The thermotransformation coefficient, Ψ_{ej} (COP_{ej}), of the ejector heat pump cycle is approximately $\Psi_{ej} = COP_e = 1 + \omega$. For various operating conditions, that is, different values of the temperature lift ΔT_{ej} , different ω and correspondingly different Ψ_{ej} or COP_{ej} are obtained. With optimal design of the flow field of the ejector elements (primary nozzle, secondary nozzle, mixing chamber, diffuser, *etc.*), high Ψ_{ej} , *i.e.* COP_{ej} , can be obtained under design operating conditions:

- $\Delta T_{ej} = T_c - T_e = 5 - 10$ K for $\omega = 4 - 8$, $\Psi_{ej} = COP_{ej} = 5 - 9$
- $\Delta T_{ej} = T_c - T_e = 10 - 20$ K for $\omega = 1 - 4$, $\Psi_{ej} = COP_{ej} = 2 - 5$
- $\Delta T_{ej} = T_c - T_e = 20 - 40$ K for $\omega = 0.5 - 1$, $\Psi_{ej} = COP_{ej} = 1.5 - 2$

Combined compressor-ejector thermocompression systems applied in industrial concentrators

Industrial concentrators are widely used in technological processes in the process industry. Usually the process of concentration – evaporation of the water from the solution is realized at defined (lower) temperatures, in order to achieve a high-quality of the product. Therefore, the temperature on the heat exchange surfaces should not be high, *i.e.* the temperature difference between the vapor that condenses and the water that evaporates from the solution should be within recommended limits. The compression ratio of a single stage centrifugal compressor is usually equal to ($\Pi = 1.7 - 2.5$), equivalent to a temperature difference, $\Delta T = T_c - T_e = 8-15$ °C. In ejector thermocompression, high efficiency is achieved for a corresponding temperature difference. During the treatment of fruit or grape concentrate, where the concentrate should retain all useful components (vitamins, minerals, aromas, *etc.*), this represents a significant benefit, therefore turbocompressor or ejector thermocompression in these concentrators is particularly suitable for application.

In concentration processes where a larger temperature difference, $\Delta T = T_c - T_e$, is allowed, implementation of a combined thermocompression system with a turbocompressor and an ejector is possible. This type of configuration is shown in fig. 8 where the first stage is turbocompressor and the second ejector on the left side and on the right side the order is alternately.

Combined compressor – ejector systems are analyzed in [14].

In systems from the process industry sector, the realization of the technological process requires electricity and thermal energy (technological steam at different pressures and hot water at different temperatures). Figure 9 shows a scheme of a combined polygeneration system for production of electricity with a GEN - electricity generator (ELG), turbo compressor and ejector thermocompression, where the waste energy from the jacket cooling (JC) of the engine and the energy from the exhaust gases (EG) is used to produce technological water vapor at different pressures and hot water at different temperatures. Basic thermal calculations, material and heat balances for the complete system and subsystems have been performed.

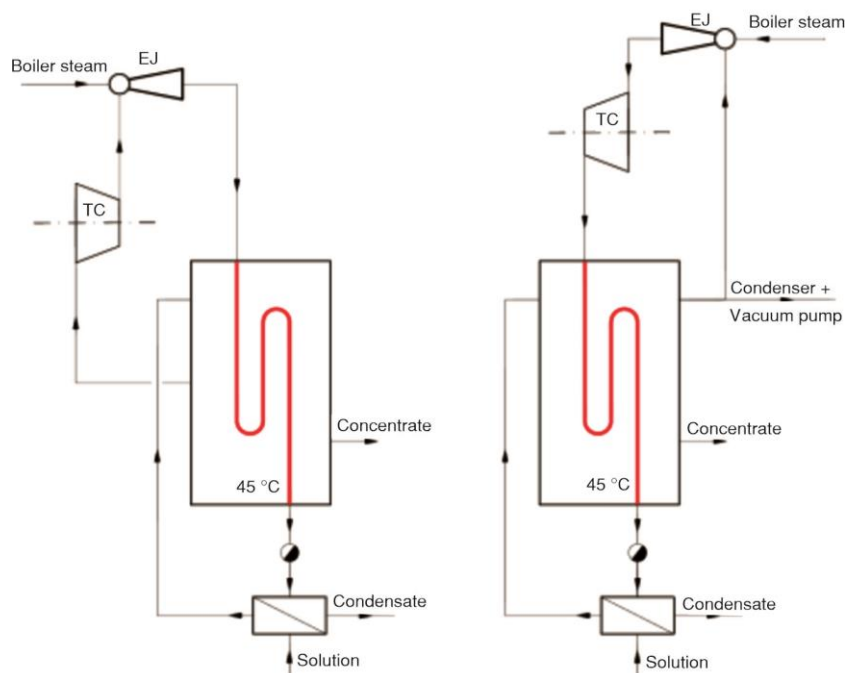

Figure 8. Combined concentrator system with turbocompressor and ejector

Gas engine – electricity generator (power production)

In the GEN 34% of the input energy of natural gas (NG – 100 % HHV – higher heating value of the NG) is transformed into mechanical energy (power). According to the analysis of the performance of GEN and the data from the manufacturers of GEN the efficiency coefficient is in the range of 32%-35 % (of HHV). The efficiency coefficient of the ELG is estimated to be 95%. In the ELG 32% of the input energy of the NG is transformed into electrical energy. The electricity is used to drive electrical machines and appliances, and the excess is delivered (sold) to the power grid.

Gas engine – electricity generator (waste heat)

The GEN waste heat with engine block cooling (JC) is estimated to be 27% and engine exhaust waste heat to be 35%. About 4% are heat losses in the environment and heat losses in the intercooler (ACHL). The waste heat from the GEN is used to produce steam with different pressures. Different performances of the steam production system at different pressures are possible, depending on the needs, that is, the requirements (capacity, operating pressure) of the process industrial system technology.

In the heat exchangers (EX1 and EX2), waste heat from the engine block cooling is used. In the first heat exchanger (EX1 - 17%), water 60/50 °C is heated, which is used for treatment – evaporation of water vapor from the solution in the first segment of the concentrator. The second heat exchanger (EX2 - 10%) represents an evaporator for the turbocompressor heat pump that supplies energy to the second segment (evaporator/condenser) of the concentrator.

In the heat exchangers (EX3 - 20%, EX4 - 7% and EX5 - 3%) the waste heat from the EG from the engine is used to obtain saturated steam with a pressure of 16 bar and a temperature

of $\approx 200\text{ }^{\circ}\text{C}$ (EX3); pressure 5 bar and temperature $\approx 150\text{ }^{\circ}\text{C}$ (EX4); pressure 1.5 bar and temperature $\approx 110\text{ }^{\circ}\text{C}$ (EX5). A portion of saturated water vapor with a pressure of 5 bar and a temperature of $\approx 150\text{ }^{\circ}\text{C}$ is used as a motive vapor in the ejector thermal compressor EJ1, which supplies thermal energy to the fourth segment of the concentrator. In the third segment of the concentrator – heat exchanger evaporator/condenser, thermocompression is realized with a turbocompressor, that compresses the water vapor from the evaporation pressure, p_e , and evaporation temperature, T_e , of the solution, to a higher pressure, p_c , corresponding to the condensation temperature, T_c , in order to obtain effective temperature difference $\Delta T = T_c - T_e$. Initial steam from heat EX4 can be used to start the concentrating process. The turbocompressor consumes about 2% of the electricity produced in the ELG. The compression ratio is 2, which means that single stage centrifugal compressors can be used.

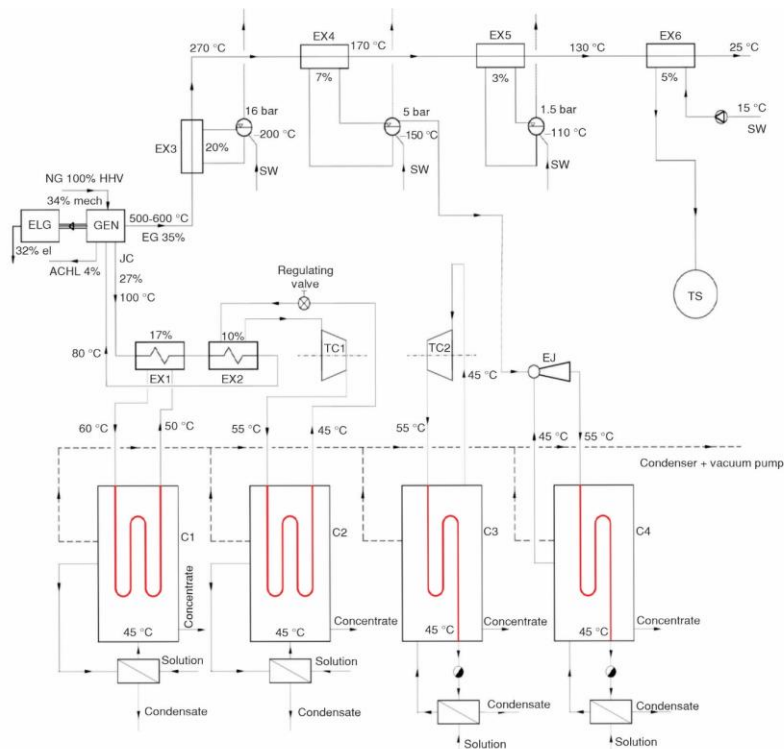

Figure 9. Polygeneration for production of electricity, technological water vapor and technological hot water with turbocompressor and ejector thermocompression

In the heat exchanger (EX6 - 5%), fig. 9, the waste heat from the EG from the engine is used to obtain sanitary and technological hot water STTW (5% HHV).

In all segments of the concentrator, the evaporation of the water vapor from the solution is realized at the same temperature ($T_e = 45\text{ }^{\circ}\text{C}$), that is, under conditions of deep vacuum, in order to obtain a high-quality of the concentrate. The temperature difference $\Delta T = T_c - T_e = 10\text{ }^{\circ}\text{C}$.

Conclusion

Industrial concentrators have a wide application in process technology in the sector of process industry. Original configurations of energy-efficient industrial vacuum concentrators,

using systems with turbocompressor and/or ejector thermocompression, are presented. In order to achieve high-quality of the product, the concentration treatment is carried out at low temperatures, that is, under conditions of deep vacuum. This especially applies to fruit and grape concentrates where the low temperature treatment is essential for retaining the nutritious values of the juice that is being concentrated. Due to the small temperature difference between the process of condensation and evaporation $\Delta T = T_c - T_e$ the required compression ratio is achieved with a single stage centrifugal compressor. Ejector thermocompression is realized with motive steam from a boiler or other heat generator, which, together with the evaporated water (waste energy) from the solution, constitutes the steam needed for the process. By applying systems with turbocompressor and/or ejector thermocompression, extremely high values of the thermotransformation coefficient are achieved, which favorably affects energy consumption and contributes to the production of a highquality product that in the same time has a competitive price. Implementation of the combined polygeneration system presented in the last section enables optimal recovery of the waste heat from the combustion in the GEN that can be used for heating energy generation multistage concentrator and for other heat demanding processes in industrial facilities of the process industry.

Nomenclature

\dot{m}	– mass-flow rate, [kgs ⁻¹]
P	– compressor power consumption, [W]
p	– pressure, [bar; Pa]
Q	– heat capacity; cooling capacity, [W]
T	– temperature, [K, °C]

Greek symbols

Δ	– difference
η	– efficiency
Ψ	– thermotransformation coefficient
ω	– entrainment ratio

Subscripts

c	condensation
e	evaporation
p	primary
w	water

Acronyms

ACHL	– air cooling heat losses
C	– concentrator
conc.	– concentrate
EG	– exhaust gases
EJ	– ejector
el	– electricity
ELG	– electricity generator
EX	– heat exchanger
GEN	– gas engine
HHV	– higher heating value
JC	– jacket cooling
mech	– mechanical
NG	– natural gas
SW	– supply water
TC	– turbocompressor
TS	– thermal storage

References

- [1] Gjerasimovski, A., *et al.*, A New Concept for Sustainable Energetic Development in Process Industry, *Proceedings, Proceasing 2020, SMEITS, Belgrade, Serbia, 2020*
- [2] Šušić, S., Petrov, S., *Fundamentals of Sugar Technology (in Serbian)*, University of Belgrade, Belgrade, Serbia, 1994
- [3] Grazzini, G., *et al.*, *Ejectors for Efficient Refrigeration: Design, Applications and Computational Fluid Dynamics*, Department of Industrial Engineering University of Florence, Florence, Italy, Springer, Ne York, USA, 2017
- [4] Akkurt, F., *et al.*, An Exergy Analysis of Solar-Assisted Ejector Cooling System for Different Area Ratios at Their Maximum Coefficients of Performance Values, *Thermal Science*, 23 (2019), 2A, pp. 717-726
- [5] Sokolov, M., Hershgal, D., Enhanced Ejector Refrigeration Cycles Powered by Low Grade Heat Part 1. Systems Characterization, *Int. J. Refrigeration*, 13 (1990), 6, pp. 351-356
- [6] Madsboll, H., Minds, G., A 2 MW Industrial Chiller using Water as Refrigerant, *Proceedings, IIR Conf. Applicaitons of Natural Refrigerants, Aarhus, Danmark, 1996*, pp. 567-576

- [7] Šarevski, M. N., Šarevski, V. N., Characteristics of Water Vapor Turbocompressors Applied in Refrigeration and Heat Pump Systems, *Int. J. Refrigeration* 35 (2012), 5, pp. 1484-1496
- [8] Šarevski, M. N., Šarevski, V. N., *Water (R718) Turbo Compressor and Ejector Refrigeration/Heat Pump Technology*, Elsevier, Amsterdam, The Netherlands, 2016
- [9] Gjerasimovski, A., *et al.*, Thermal Characteristics of Combined Compressor – Ejector Refrigeration/Heat Pump Systems for HVAC&R, *Thermal Science*, 28 (2024), 2C, pp. 1577-1587
- [10] Yulong, L., *et al.*, Experimental Study of Waste Concentration by Mechanical Vapor Compression Technology, *Desalination*, 361 (2015), Apr., pp. 46-52
- [11] Gjerasimovski, A., *et al.*, Characteristics of R718 Thermal Systems and Possibilities for Implementation in Refrigeration/Heat Pump Systems in Buildings, *Proceedings*, 51st International HVAC&R Congress and Exhibition, KGH 2020, SMEITS, Belgrade, Serbia
- [12] Zhao, D., *et al.*, Design and Control of an Ultra High Speed Turbo Compressor for the Air Management of Fuel Cell Systems, *Proceedings*, Transportation Electrification Conference and Expo (ITEC), Dearborn, Mich., USA, 2012
- [13] Šarevski, M. N., Šarevski, V. N., Thermal Characteristics of High-Temperature R718 Heat Pumps with Thermal Vapor Recompression, *Applied Thermal Engineering*, 117 (2017), May, pp. 355-365
- [14] Gjerasimovski, A., *et al.*, Energy Efficiency of Combined Compressor-Ejector Refrigeration Systems, *Proceedings*, 52nd International HVAC&R Congress and Exhibition, KGH 2021, Smeits, Belgrade, Serbia, pp. 47-57