

Nestacionarno strujanje fluida u paralelnom cevovodu izrađenom od različitih materijala

Transient Fluid Flow in Parallel Pipeline Designed of Pipes with Different Materials

Marija Lazarevikj, Viktor Iliev, Valentino Stojkovski

Ss. Cyril and Methodius University in Skopje, Faculty of Mechanical Engineering-Skopje, Department of Hydraulic Engineering and Automation

Rezime - Nestacionarno strujanje fluida i pojava hidrauličnog udara u svojim specifičnostima uključuju uslove okruženja u kojem se odvija strujanje fluida. Raznolikost materijala za izgradnju cevovoda (čelik, polietilen ili drugi materijal) definiše uslove za razvoj hidrauličnog udara. Predmet istraživanja u ovom radu su paralelno vezani cevovodi izrađeni od različitih materijala i međusobni uticaj u uslovima nestacionarnog strujanja fluida. Izvršeno je numeričko istraživanje na dugim (pravim) cevovodima. Korišćen je softverski paket AFT-Impulse koji je već testiran uporednim eksperimentalno izmerenim vrednostima. Model za analizu razmatra paralelno vezane cevovode od čelika i polietilena. Rezultati simulacionih uslova dati su kroz uporedne dijagrame, gde se interaktivni uticaj jasno i nedvosmisleno otkriva. Uslovi eksploatacije i interaktivni uticaj dati su u komentaru i zaključku ovog rada.

Cljučne reči – građevinski materijal, protok fluida, cevovod, simulacije, nestacionarno strujanje fluida, hidraulični udar

Abstract - Transient fluid flow and the occurrence of water hammer in their specifics include the conditions of the environment in which the flow takes place. The variety of pipeline construction material (steel, polyethylene or other material) defines the conditions for the development of water hammer. The construction of parallel hydraulically connected pipelines from different materials and mutual influence in the conditions of transient fluid flow conditions of operation is the subject of research in this paper. The research was performed numerically on long (line) pipelines. The AFT-Impulse software package was used, which had already been tested with comparative experimentally measured values. The analysis model considers pipelines made of steel and polyethylene material in parallel hydraulic connection. The results of the simulation conditions are given through comparative diagrams, where the interactive influence is clearly and unambiguously revealed. The conditions of exploitation and interactive influence are given in the commentary and conclusion of this paper.

Index Terms - constructive material, fluid flow, pipeline, simulations, transient fluid flow, water hammer

I INTRODUCTION

Water hammer is result of sudden change in the liquid flow rate induces substantial increase or decrease of pressure in hydraulic pipeline systems. This phenomenon may be result of valve closure or opening and changing of the operating mode of hydraulic turbomachinery. Uncontrolled water hammer can disturb operation of the hydraulic systems and, in the worst case, destroy and damage system components. Water hammer pressure rise or drop may be controlled by installing protecting devices for appropriate control of operating regimes [1], [2]. The classical water hammer may be affected by transient cavitation and water column separation (WCS), unsteady skin friction effects, viscoelastic behavior of the pipe wall and fluid-structure interaction [3].

Mathematical model for transient fluid flow in pipe is obtained using a one-dimensional approach of modeling with conservation laws for mass flow (continuity equation (eq.1)) and momentum (momentum equation (eq.2)) [4]:

$$\frac{\partial H}{\partial t} + a^2 \frac{\partial Q}{\partial x} / (g \cdot A \cdot \rho) = 0 \quad (1)$$

$$\frac{\partial H}{\partial x} + \frac{\partial Q}{\partial t} / (g \cdot A \cdot \rho) + \lambda \cdot Q \cdot |Q| / (2 \cdot g \cdot D \cdot A^2) = 0 \quad (2)$$

In equation (1) and (2), Q is discharge, H denotes the piezometric head (pressure) at the centerline of the pipeline at location x and time t , D is the pipeline diameter, λ is the friction factor in the Darcy-Weisbach formula, x is the distance along the centerline of the pipe, g is the gravity acceleration and a is pressure wave speed.

The hyperbolic set of equation (1) and (2) are quasi-linear hyperbolic functions and can't be solved with a general analytical solution, but given initial and boundary conditions, can be calculated numerically.

The pressure wave speed in the system is calculated according to following equation (3), [4]:

$$a^2 = 1 / (1/K + D/\delta \cdot E) \quad (3)$$

In equation (3) K represents bulk modulus of elasticity of the fluid, ρ is density of the fluid, E is young's (elasticity) modulus of pipe material, δ is pipe equivalent wall-thickness.

The numerical investigation in this paper is focused on determining the impact of the pipeline construction on the transient flow regimes that occur during closing or opening the valve in pipeline system. The pipeline design is defined by the choice of pipeline wall material, thus pipeline made of one material, as well as pipeline constructed from different materials are both numerically studied.

II NUMERICAL SETUP AND TEST CASES

The pipeline sections materials are selected in order to achieve a significant difference in the modulus of elasticity which implies different speed of propagation of the hydraulic shock wave, and different deformability of the pipeline wall. These parameters affect the transient flow regimes.

In this paper, the transition modes in the pipeline systems are analyzed when:

- the closing time (t_z) and the opening time (t_o) of the pipeline is 8 seconds (linearly);
- the law of fluid flow rate change is linear and the flow rate is $0,2 \text{ m}^3/\text{s}$;
- gravitational water flow from a tank at 60 m head;
- parallel pipeline sections have the same length of 2000 m, while the connecting pipes in the pipeline are 1000 m long. The section lengths are chosen to ensure a difference in the time of presence of the hydraulic shock wave.

The parameters that are defining the pipeline sections i.e. type of material, inner diameter, wall thickness and wave speed are given in table 1.

Table 1. Parameters of the pipeline sections

Pipe material	Inner diameter ID (mm)	Wall thickness δ (mm)	Elasticity modulus (MPa)	Wave speed a (m/s)
HDPE	245	13,8	1071,5	261
HDPE	387,5	22,5	1071,5	265,8
STEEL	254,5	9,3	203424	1281,5
STEEL	387	9,5	203559	1220

Different cases of connections of the pipeline sections were numerically investigated:

- Case 1. Pipeline consisting of parallel sections with joint points;
- Case 2. Pipeline consisting of parallel sections with an inflow junction to the parallel sections and two independent outlets. The closing/opening of the valves in the individual sections is performed at the same time;
- Case 3. Pipeline consisting of parallel sections with an outflow junction from the parallel sections;
- Case 4. Pipeline with sequentially connected sections.

The choice of the pipeline sections materials provides a pipeline construction of homogeneous material – only steel or only polyethylene, or a pipeline construction of combined materials – individual sections are made of different materials and each one specifically affects the transient regimes.

The first configuration is set to provide equal hydraulic conditions in the parallel pipe sections in steady state flow at both the inlet and outlet of the sections (with mutual junctions). The system (Figure 1) provides non-simultaneous transient processes with wave interference at the joint points.

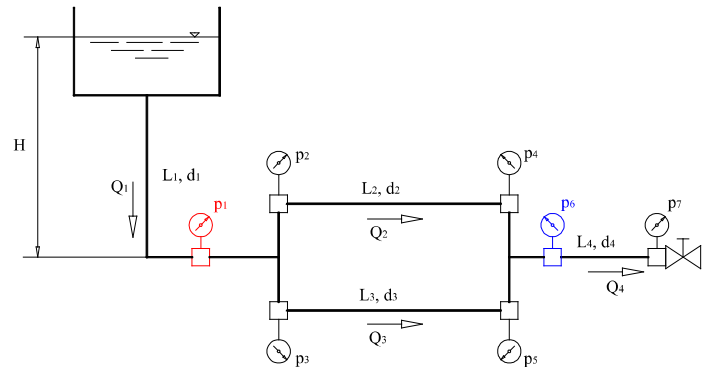

Figure 1. Pipeline with parallel branches and same inflow-outflow junction (Case 1)

The four analyzed combinations of materials for the described first configuration are given in table 2.

Table 2. Variants of first pipeline configuration (Case 1)

MODE	P1	P2	P3	P4
M1	C	C	C	C
M2	C	PE	C	C
M3	C	PE	PE	C
M4	PE	PE	PE	PE

C- steel pipe; PE-polyethylene pipe

The second pipeline configuration (Figure 2) is set to ensure equal hydraulic conditions of the parallel branches during steady state flow at the inlet junction of the sections (mutual inflow junction). The system aims to provide non-simultaneous arrival of the hydraulic shock wave (in the first phase of the water hammer) in order to see the impact of the counter pressure wave in the pipe section where the wave speed is smaller.

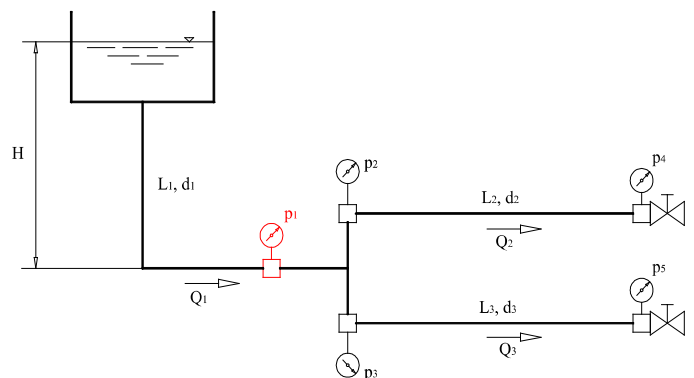

Figure 2. Pipeline with parallel branches and same inflow junction (Case 2)

The four analyzed combinations of materials for the described second pipeline configuration are given in table 3.

Table 3. Variants of second pipeline configuration (Case 2)

MODE	P1	P2	P3
M1	C	C	C
M2	C	PE	C
M3	C	PE	PE
M4	PE	PE	PE

C- steel pipe; PE-polyethylene pipe

The third pipeline configuration (Figure 3) is set to ensure equal hydraulic conditions of the parallel branches during steady state flow at the inlet and outlet junction of the sections (with mutual outflow junction).

The system aims to determine the impact of the transient states when pressure waves are joining at a junction.

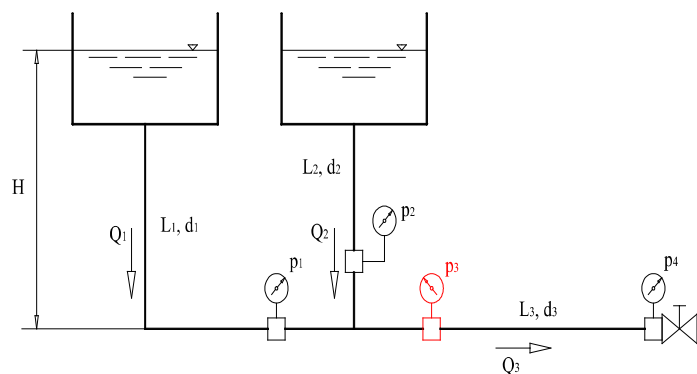

Figure 3. Pipeline with parallel branches and same outflow junction (Case 3)

The four analyzed combinations of materials for the described third pipeline configuration are given in table 4.

Table 4. Variants of third pipeline configuration (Case 3)

MODE	P1	P2	P3
M1	C	C	C
M2	PE	C	C
M3	PE	PE	C
M4	PE	PE	PE

C- steel pipe; PE-polyethylene pipe

The fourth pipeline configuration (Figure 4) consists of sequentially connected sections made of different materials. The system aims to determine the impact of the sequence of connection in the pipeline construction.

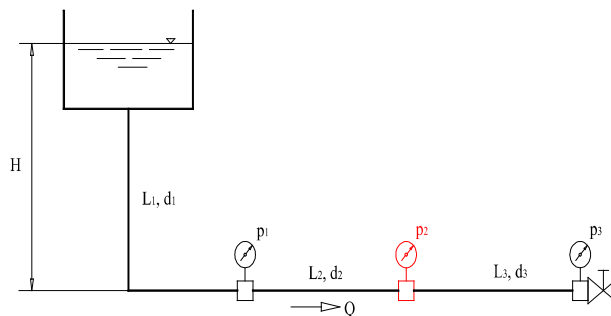

Figure 4. Pipeline with serial connection of branches (Case 4)

The four analyzed combinations of materials for the described fourth pipeline configuration are given in table 5.

Table 5. Variants of third pipeline configuration (Case 4)

MODE	P1	P2	P3
M1	PE	PE	PE
M2	PE	C	PE
M3	C	PE	C
M4	C	C	C

C- steel pipe; PE-polyethylene pipe

III RESULTS AND DISCUSSION

Numerical simulations of the transient regimes are performed using the AFT Impulse software package. First, the minimum time step Δt needs to be determined for the iterative calculation. This time step is determined from the Lewy-Courant criteria [2], that is $Cr < 1$ [2].

$$\Delta t < L/(a \cdot n) \text{ and } Cr = a \cdot \Delta t / (\Delta x) < 1 \quad (4)$$

where n represents the number of segments that pipeline is divided in, while Δx is the length of one segment.

CASE 1:

The results from the numerical simulations of the transient regimes are presented by the change of the gauge pressure p_1 which defines the flow conditions at the inlet junction, and the pressure p_6 which defines the flow conditions at the outlet junction.

A) CLOSING OF PIPELINE

When closing the pipeline, the variation of the gauge pressure p_1 in front of the inlet junction for pipeline of same and different material is shown on Figure 2 a) and b) respectively, while the variation of the gauge pressure p_6 at the outlet junction for pipeline of same and different material is shown on Figure 3 a) and b) respectively.

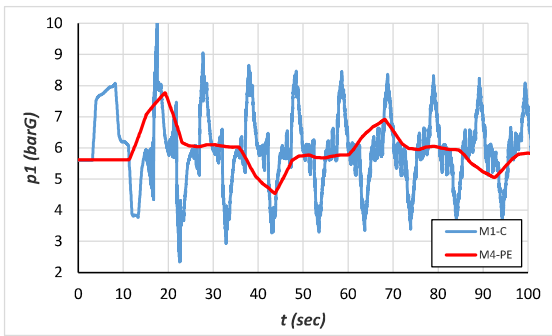

a) pipeline of same material (M1-steel and M4-polyethylene)

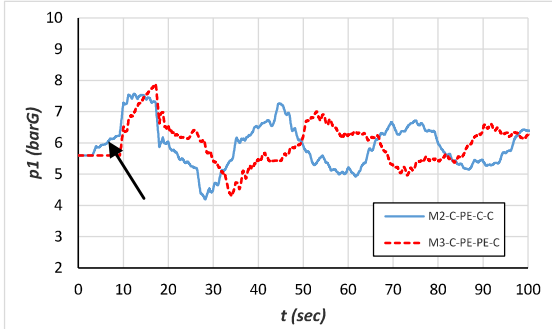

b) pipeline of different wall material at parallel branches (M2 and M3)

Figure 5. Pressure variation in transient flow of closing pipeline at manometer p_1 – inlet junction (Case 1)

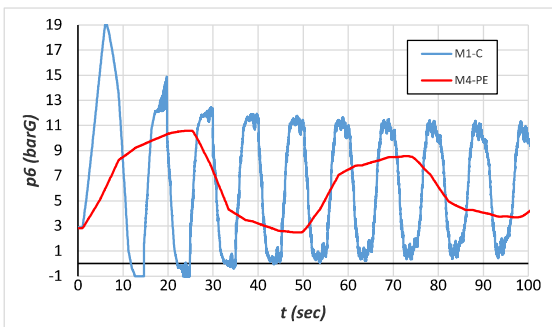

a) pipeline of same material (M1-steel and M4-polyethylene)

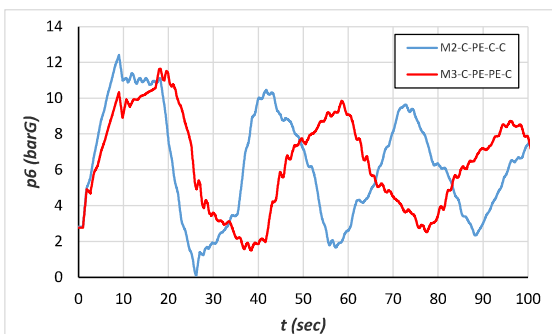

b) pipeline of different wall material at parallel branches (M2 and M3)

Figure 6. Pressure variation in transient flow of closing pipeline at manometer p_6 – outlet junction (Case 1)

According to the numerically obtained results that describe the transient states during valve closure, it can be noted that:

- in terms of pressure variation caused by the water hammer, the pipeline construction with polyethylene pipes induces lower pressure rise in the system;
- the configuration with pipe sections with different materials (adding polyethylene pipes) has positive effects on lowering the induced pressure rise;
- the configuration with pipe sections with different materials causes different law of pressure change, both in amplitude and frequency of the transient states;
- during the non-simultaneous hydraulic shock wave propagation, the appearance of a counter-wave due to the pressure increase, while the first (basic) one has not arrived, causes a decrease in the pressure rise in the observed section (Figure 5 b);
- in case of the mode M1 (closing of the valve(pipeline)) are affected by transient cavitation and water column separation at location p_6 .

B) OPENING OF PIPELINE

When opening the pipeline, the variation of the gauge pressure p_1 in front of the inlet junction for pipeline of same and different material is shown on Figure 7 a) and b) respectively, while the variation of the gauge pressure p_6 at the outlet junction for pipeline of same and different material is shown on Figure 8 a) and b) respectively.

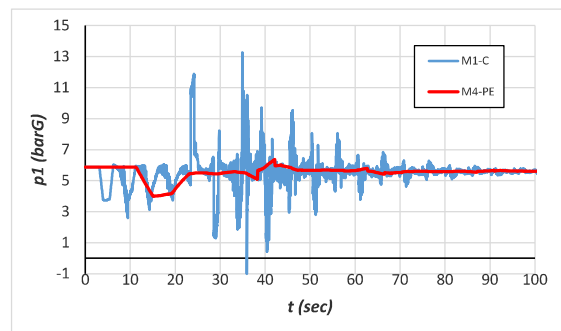

a) pipeline of same material (M1-steel and M4-polyethylene)

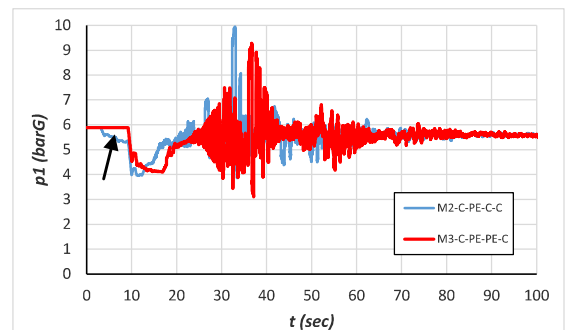

b) pipeline of different wall material at parallel branches (M2 and M3)

Figure 7. Pressure variation in transient flow of opening pipeline at manometer p_1 – inlet junction (Case 1)

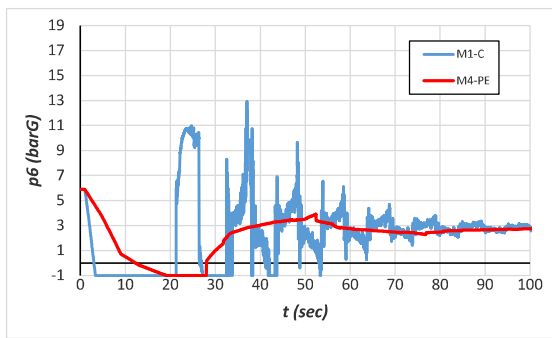

a) pipeline of same material (M1-steel and M4-polyethylene)

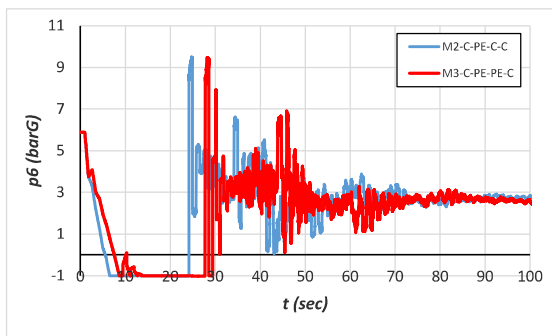

b) pipeline of different wall material at parallel branches (M2 and M3)

Figure 8. Pressure variation in transient flow of opening pipeline at manometer p_6 – outlet junction (Case 1)

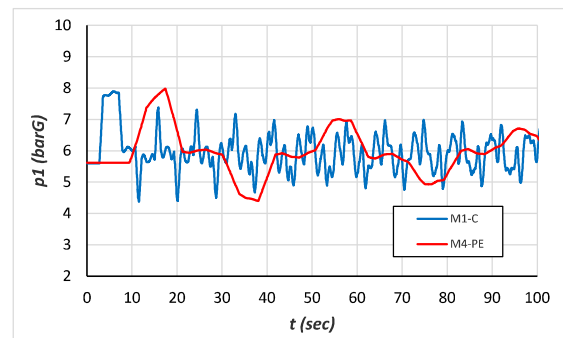

a) pipeline of same material (M1-steel and M4-polyethylene)

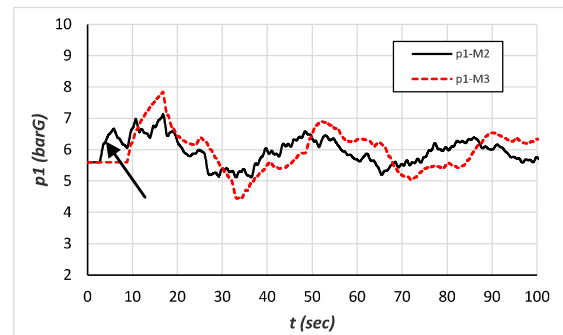

b) pipeline of different wall material at parallel branches (M2 and M3)

Figure 9. Pressure variation in transient flow of closing pipeline at manometer p_1 – inlet junction (Case 2)

According to the numerically obtained results that describe the transient states during valve opening, it can be noted that:

- in terms of pressure variation caused by the ‘negative’ water hammer, the pipeline construction with polyethylene pipes induces decrement of the pressure rise in the system;
- the configuration with pipe sections with different materials (adding polyethylene pipes) has positive effects on lowering the loads in the system;
- during the non-simultaneous hydraulic shock wave propagation, the appearance of a counter-wave due to the pressure increase, while the first (basic) one has not arrived, causes a decrease in the pressure rise in the observed section (Figure 4 b);
- in case of the opening of the valve(pipeline)) the all mode of simulations are affected by transient cavitation and water column separation at location p_6 .

CASE 2:

CLOSING-OPENING OF PIPELINE

The transient fluid flow conditions during valve closure and valve opening are given in Figures 9 and 10, respectively presented by the gauge pressure p_1 variation.

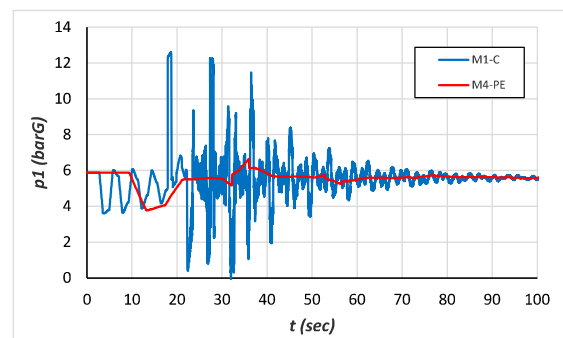

a) pipeline of same material (M1-steel and M4-polyethylene)

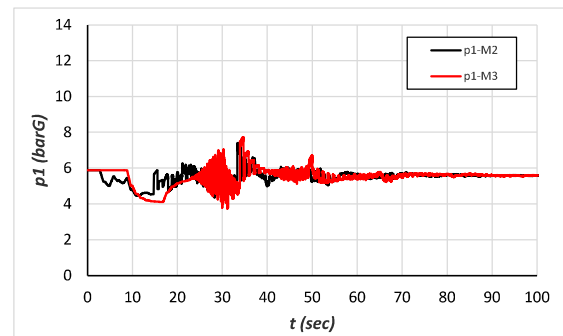

b) pipeline of different wall material at parallel branches (M2 & M3)

Figure 10. Pressure variation in transient flow of opening pipeline at manometer p_1 – inlet junction (Case 2)

The results from the numerical simulations of valve closure show that the pipeline construction does not affect the pressure rise intensity i.e. the amplitude, but the frequency of the transient states (Figure 9 a).

The non-simultaneous arrival of the hydraulic shock wave from the parallel branches into the junction reduces the pressure amplitude (Figure 9 b).

The results from the simulation of transient fluid flow during valve opening show high pressure oscillations in the pipeline designed only from steel pipes (Figure 10 a), while adding polyethylene pipe significantly decreases the pressure amplitude (Figure 10 b).

CASE 3:

CLOSING-OPENING OF PIPELINE

The transient fluid flow conditions during valve closure and valve opening are given in Figures 11 and 12, respectively presented by the gauge pressure p_3 variation.

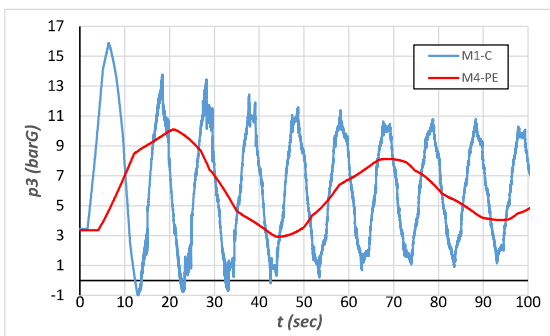

a) pipeline of same material (M1-steel and M4-polyethylene)

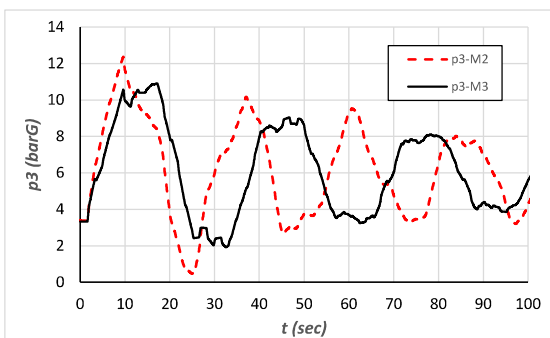

b) pipeline of different wall material at parallel branches (M2 and M3)

Figure 11. Pressure variation in transient flow of closing pipeline at manometer p_3 – outlet junction (Case 3)

The results from the numerical simulations of valve closure show that:

- the pipeline construction of only steel pipes causes high pressure amplitude (Figure 11 a). If the pipeline is designed of polyethylene pipes, the pressure amplitude is lower and there is no vacuum pressure;

- the pipeline construction of different materials pipes provides more favorable transient states compared to the construction of steel pipes only;
- in case of the mode M1 are affected by transient cavitation and water column separation at location p_3 .

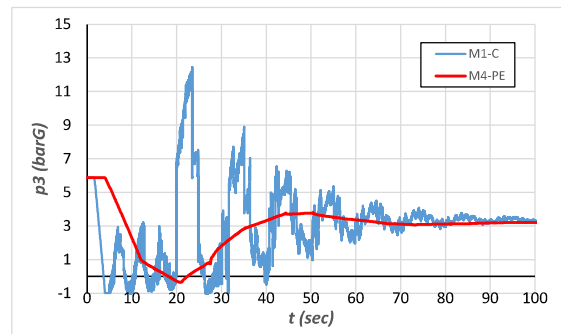

a) pipeline of same material (M1-steel and M4-polyethylene)

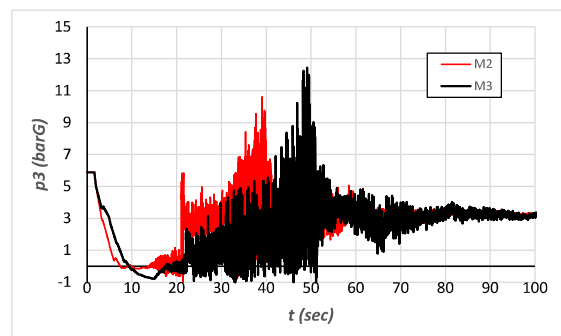

b) pipeline of different wall material at parallel branches (M2 and M3)

Figure 12. Pressure variation in transient flow of opening pipeline at manometer p_3 – outlet junction (Case 3)

The results from the numerical simulations of valve opening show that:

- the pipeline construction of only steel pipes causes high pressure amplitude with reach under pressure (Figure 12 a). If the pipeline is designed of polyethylene pipes, the pressure amplitude is lower and there is vacuum pressure with low magnitude;
- the pipeline construction of different materials pipes does not provide more favorable transient states in the pipeline (Figure 12 b). Best conditions are achieved with construction of only polyethylene pipes;
- in case of the mode M1 and M3 are affected by transient cavitation and water column separation at location p_3 .

CASE 4:

CLOSING-OPENING OF PIPELINE

The transient fluid flow conditions during valve closure and valve opening are given in Figures 13 and 14, respectively presented by the gauge pressure p_2 variation.

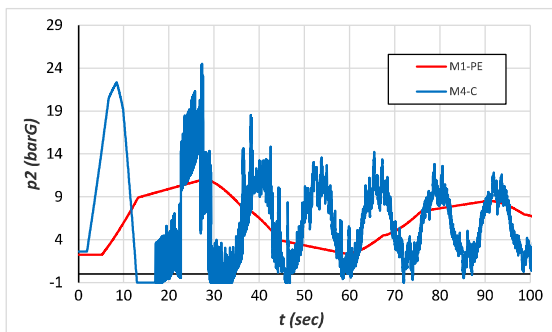

a) pipeline of same material (M1-steel and M4-polyethylene)

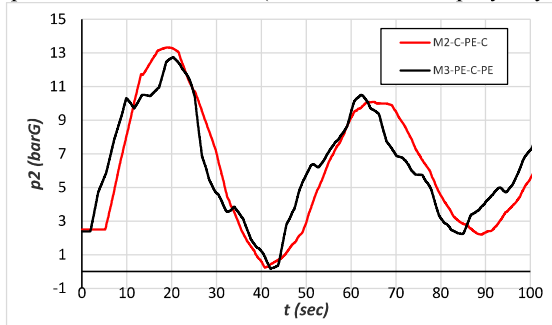

b) pipeline of different wall material at serial section connection (M2 and M3)

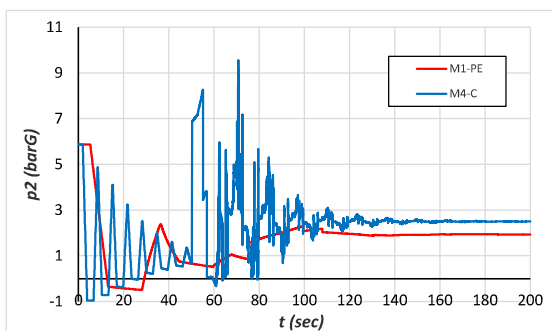
Figure 13. Pressure variation in transient flow of closing pipeline at manometer p_2 – section on pipeline (Case 4)

a) pipeline of same material (M1-steel and M4-polyethylene)

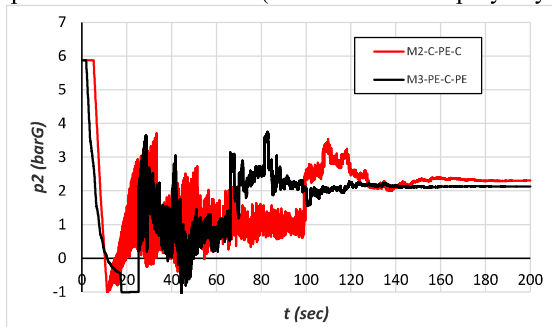

b) pipeline of different wall material at serial section connection (M2 and M3)

Figure 14. Pressure variation in transient flow of opening pipeline at manometer p_2 – section on pipeline (Case 4)

The results from the numerical simulations of valve closure show that the pipeline construction from only steel pipes causes high

pressure amplitude and high intensity of water column separation (Figure 13 a). If the same pipeline configuration is constructed from polyethylene pipes, the pressure rise is considerably smaller. When changing the sequence of the pipe sections made of different materials, there is a difference in the hydraulic shock wave shape.

The transient flow when opening the valve shows high pressure oscillations in the pipeline made of steel sections only (Figure 14 a), while adding a polyethylene section significantly decreases the pressure amplitude. The sequence of the pipe sections influences the transient states.

IV CONCLUSION

The numerical models considered in this paper provide information about the transient states in rigid (steel) and elastic (polyethylene) pipeline, and the influence of the pipeline construction with different connection of its sections which are made of different materials. The numerical calculations were performed for both opening and closing of the pipeline system. The effects from the transient states are presented by the pressure variation in selected characteristic points in the system and they show that adding an elastic pipe section as a part of the pipeline or elastic pipes defining the whole pipeline reduce the water hammer effects. According to the numerically obtained results, decreasing of the water hammer effects can be achieved by installing an elastic pipe section, i.e. the choice of pipe material type can help controlling the water hammer. Considering the results in this paper, a recommendation can be made for future solutions of pipeline systems in dealing with water hammer effects to construct combined systems including elastic pipes.

LITERATURA/REFERENCES

- [1] Wylie, E.B., Streeter, V. L. *Fluid Transients in Systems*, Prentice-Hall Inc., Englewood Cliffs, 1993.
- [2] Chaundry, M.H. *Applied hydraulic transients*, Van Nostrand Reinhold Co., New York, 1979.
- [3] Bergant, A., Tijsseling, A.S., Vitkovsky, J.P., Covas, D.I.C., Simpson, A.R., Lambert, M.F. Parameters affecting water hammer wave attenuation, shape and timing. Part 1, Mathematical tools and Part 2: Case studies. *IAHR Journal of Hydraulic Research*, Vol. 46, No. 3, Part 1, pp. 373-381, Part 2, pp. 382-391, 2008. <https://doi.org/10.3826/jhr.2008.2848> and <https://doi.org/10.3826/jhr.2008.2847>
- [4] Wylie E.B., Streeter V.L. *Fluid Transients*, University of Michigan, 2001.
- [5] Stojkovski, V., Kostikj, Z., Iliev, V., Lazarevikj, M. Comparison of measured and numerical results for unsteady fluid flow at water distribution system, in Proc. *5th International Scientific Conference COMETA 2020*, Jahorina, 26-28. November 2020.
- [6] Stojkovski, V., Kostić, Z., Nošpal A. CFD analiza strujnog prostora u odnosu na kavitacijski režim rada kod Howell Bunger ventila sa ugrađenim deflektorom, *Energetika, ekonomija, ekologija*, Vol. XIII, No. 2, pp. 90-93, 2011.
- [7] Chaundry, M.H. *Applied hydraulic transients*, Van Nostrand Reinhold company, New York, 1979.
- [8] Stojkovski V., Kostic, Z. Prediction of the energy production from small hydropower plants, *Energetika, ekonomija, ekologija*, Vol. XVII, No. 1-2, pp. 117-121, 2015.
- [9] Stojkovski V., Stojkovski F. Influence of water supply system on efficiency at run-of-river small hydropower plant, in Proc. *6th International conference & workshop REMOO 2016*, Budva, 18-20. mart 2016.
- [10] Wylie, E.B., Streeter, V.I. *Fluid transient*, Mc.Graw-Hill, New York, 1978.
- [11] Zaruba, L. *Water hammer in pipe-line system*, Elsevier, Amsterdam, 1993.
- [12] Iliev, V., Nachevski, G. Water hammer in high pressure steel pipelines, in Proc. *6th International Metallurgical Congress, PEM-7*, pp. 111, 2014.

- [13] Iliev V., Popovski P., Markov Z. Water hammer analysis using characteristics method and numerical simulation, *Mechanical Engineering - Scientific Journal*, Vol. 31, No. 1-2, pp. 53-62, 2013.
- [14] Iliev V., Popovski P., Markov Z. A dynamic behavior of low head hydropower plant during the transient operational regimes, in Proc. 6th *International meeting of the workgroup on cavitation and dynamic problems in hydraulic machinery and systems*, Ljubljana, 9-11. September 2015.
- [15] Iliev, V., Ivljanin, B., Markov, Z., Popovski, P. Sensitivity of transient phenomena analysis of the Francis turbine power plants, *International Journal of Engineering Research and Applications*, Vol.5, No. 8, pp. 1480-1488, 2015.
- [16] Iliev, V., Popovski, P., Markov, Z. A comparison of numerical prediction and the experimental dynamic behavior at transient regimes of hydropower

plant, *Technics Technologies Education Management (TTEM)*, 9 (1), pp.3-10, 2014.

AUTORI/AUTHORS

Marija Lazarevikj, Assistant, Faculty of Mechanical Engineering – Skopje, Department of Hydraulic Engineering and Automation, marija.lazarevikj@mf.edu.mk

Viktor Iliev Ph.D., Professor, Faculty of Mechanical Engineering – Skopje, Department of Hydraulic Engineering and Automation, viktor.iliev@mf.edu.mk

Valentino Stojkovski Ph.D., Professor, Faculty of Mechanical Engineering – Skopje, Department of Hydraulic Engineering and Automation, valentino.stojkovski@mf.edu.mk