

See discussions, stats, and author profiles for this publication at: <https://www.researchgate.net/publication/341781542>

# DESIGN OPTIMIZATION AND TESTING OF 200 AMPS BOOSTER TRANSFORMER BASED ON DIFFERENTIAL EVOLUTION ALGORITHM

Article · May 2020

CITATIONS

0

READS

85

2 authors:



[Rasim Salkoski](#)

University for Information Science and Technology "St. Paul the Apostle"

15 PUBLICATIONS 17 CITATIONS

[SEE PROFILE](#)



[Ivan Chorbev](#)

Ss. Cyril and Methodius University in Skopje

115 PUBLICATIONS 878 CITATIONS

[SEE PROFILE](#)

Some of the authors of this publication are also working on these related projects:



Covihealth [View project](#)



COST15120 OpenMultiMed [View project](#)

## DESIGN OPTIMIZATION AND TESTING OF 200 AMPS BOOSTER TRANSFORMER BASED ON DIFFERENTIAL EVOLUTION ALGORITHM

*Rasim Salkoski<sup>1</sup>, Ivan Chorbev<sup>2</sup>*

<sup>1</sup>University for Information Science and Technology, Building at ARM, Ohrid

<sup>2</sup>Faculty of computer science and engineering, University of Ss Cyril and Methodius, "Rugjer Boshkovikj" 16, P.O. Box 393, Skopje

e-mails: rasim.salkoski@uist.edu.mk, ivan.chorbev@finki.ukim.mk  
R. of North Macedonia

**Abstract:** Differential Evolution is a population based search algorithm, which is an improved version of Genetic Algorithm. Simulations carried out involved solving optimization problems using Penalty function method. The optimization techniques based Differential Evolution used in the design of the booster transformer result in saving of supply electric energy for the railway power supply systems. Special interest is given to the minimization of production and exploitation costs of the booster transformer. The optimization algorithm based on Differential Evolution is applied to the problem of minimizing the cost of the active parts of the booster transformer. Verification of results is confirmed in an independent accredited laboratory.

**Key words:** Differential Evolution Algorithm, Booster Transformer, Optimization techniques, Railway, Temperature rise Test, Impulse Test

### 1. INTRODUCTION

Evolutionary algorithms are a class of stochastic search and optimization methods, based on the principles of natural biological evolution. They have received considerable interest in the field of optimization for many years. In particular, there has been a focus on global optimization of numerical problems for which exact and analytical methods do not apply. Since the mid-1960s, many general-purpose EAs and their variants have been proposed for finding near-optimal solutions to this class of problems. Many efforts have also been devoted to compare these algorithms to each other. Conclusion was that the performance of Differential Evolution (DE) is outstanding in comparison to the other tested algorithms. The DE algorithm, which was introduced by Storn and Price (1995) [6], shares similarities with traditional EAs. However, it does not use binary

encoding as a simple genetic algorithm (Michalewicz, 1996) [23] and it does not use a probability density function to self-adapt its parameters as an Evolution Strategy (Schwefel, 1995) [31]. Instead, DE as well as its variant methods performs mutation based on the distribution of the solutions in the current population. In this way, search directions and possible step sizes depend on the location of the individuals selected to calculate the mutation values. The use of the mutation scheme in DE and its variants gives rise to a faster convergence rate.

Solutions generated by the computers are set of different booster transformer designs (by changing current density, flux density, core dimensions, type of magnetic material and so on) termed good or bad in terms of an objective, which is often the cost of fabrication, amount of waste material, efficiency of a process, product reliability, or other factors [9, 19, 20, 21]. One area of great importance that can benefit from the effectiveness of such algorithms is AC railway power supply systems. The work in this paper introduces the use of an evolutionary algorithm, titled Differential Evolution (DE) in conjunction with the penalty function approach to minimize the booster transformer cost while meeting international standards and customer needs [1, 2, 3, 4, 6, 7, 8, 12, 13]. The method is applied to the design of a booster transformer and the results are compared with a heuristic transformer design optimization methodology, resulting in significant cost savings.

## 2. DIFFERENTIAL EVOLUTION (DE)

Differential Evolution (DE) algorithm is a population-based stochastic method for global optimization developed by Rainer Storn and Kenneth Price [7] for optimization problems over continuous domains. The original version of DE with constituents can be defined as follows :

### 2.1. The Population

$$\begin{aligned} P_{x,g} &= (\mathbf{x}_{i,g}), \quad i=0,1,\dots, NP, \quad g=0,1,\dots, g_{max} \\ \mathbf{x}_{i,g} &= (x_{j,i,g}), \quad j=0,1,\dots, D-1. \end{aligned} \quad (1)$$

where  $NP$  is the number of population vectors,  $g$  defines the generation counter, and  $D$  the number of parameters.

### 2.2. The initialization of the population through

$$x_{j,i,0} = rand_j [0,1] \cdot (b_{j,U} - b_{j,L}) + b_{j,L} . \quad (2)$$

The D-dimensional initialization vectors,  $\mathbf{b}_L$  and  $\mathbf{b}_U$  indicate the lower and upper bounds of the parameter vectors  $\mathbf{x}_{i,j}$ . The random number generator,  $rand_j [0,1)$ , re-returns a uniformly distributed random number from within the range  $[0,1)$ , i.e.,  $0 \leq rand_j [0,1) < 1$ . Indication that a new random value is generated for each

parameter is denoted by the subscript  $j$ . This template was designed for two affiliations.

### 2.3. The perturbation of a base vector $y_{i,g}$ by using a difference vector mutation

$$\mathbf{v}_{i,g} = \mathbf{y}_{i,g} + F \cdot (\mathbf{x}_{r_1,g} - \mathbf{x}_{r_2,g}). \quad (3)$$

to generate mutation vector  $\mathbf{v}_{i,g}$ . The difference vector indices,  $r_1$  and  $r_2$ , are randomly selected once per base vector. Setting  $\mathbf{y}_{i,g} = \mathbf{x}_{r_0,g}$  defines what is often called classic DE where the base vector is also a randomly chosen population vector. The random indexes  $r_0$ ,  $r_1$ , and  $r_2$  should be mutually exclusive. This template was designed for two affiliations.

### 2.4. Diversity enhancement

The classic variant of diversity enhancement is crossover which mixes parameters of the mutation vector  $\mathbf{v}_{i,g}$  and the so-called **target vector**  $\mathbf{x}_{i,g}$  in order to generate the **trial vector**  $\mathbf{u}_{i,g}$ . The most common form of crossover is uniform and is defined as

$$\mathbf{u}_{i,g} = u_{j,i,g} = \begin{cases} v_{j,i,g} & \text{if } (\text{rand}_j [0,1] \leq CR) \\ x_{j,i,g} & \text{otherwise} \end{cases} \quad (4)$$

In order to prevent the case  $\mathbf{u}_{i,g} = \mathbf{x}_{i,g}$  at least one component is taken from the mutation vector  $\mathbf{v}_{i,g}$ , a detail that is not expressed in (4).

### 2.5. Selection

DE uses simple one-to-one survivor selection where the trial vector  $u_{i,g}$  competes against the target vector  $x_{i,g}$ . The vector with the lowest objective function value survives into the next generation  $g + 1$ .

$$\mathbf{x}_{i,g+1} = \begin{cases} \mathbf{u}_{i,g} & \text{if } f(\mathbf{u}_{i,g}) \leq f(\mathbf{x}_{i,g}) \\ \mathbf{x}_{i,g} & \text{otherwise.} \end{cases} \quad (5)$$

Along with the DE algorithm came a notation (5) to classify the various DE-variants. The notation is defined by DE/ $x$ / $y$ / $z$  where  $x$  denotes the base vector,  $y$  denotes the number of difference vectors used, and  $z$  representing the crossover method. For ex-ample, DE/rand/1/bin is the shorthand notation for (1) through (5) with  $\mathbf{y}_{i,g} = \mathbf{x}_{r_0,g}$ . DE/best/1/bin is the same except for  $\mathbf{y}_{i,g} = \mathbf{x}_{best,g}$ . In this case  $\mathbf{x}_{best,g}$  represents the vector with the lowest objective function value evaluated so far. With today's extensions of DE, the shorthand notation DE/ $x$ / $y$ / $z$  is not sufficient any more, but a more appropriate notation has not been defined yet.

Price and Storn [7] gave the working principle of DE with single strategy. They suggested ten different strategies for DE. Different strategies can be adopted in the DE algorithm depending upon the type of problem to which DE is applied.

The strategies can vary based on the vector to be perturbed, number of difference vectors considered for perturbation, and finally the type of crossover used. The following are the ten different working strategies: 1. DE/best/1/exp, 2. DE/rand/1/exp, 3. DE/rand-to-best/1/exp, 4. DE/best/2/exp, 5. DE/rand/2/exp, 6. DE/best/1/bin, 7. DE/rand/1/bin, 8. DE/rand-to-best/1/bin, 9. DE/best/2/bin, 10. DE/rand/2/bin. As it is explained the general convention used above is DE/ $x/y/z$ . DE stands for Differential Evolution,  $x$  represents a string denoting the vector to be perturbed,  $y$  is the number of difference vectors considered for perturbation of  $x$ , and  $z$  stands for the type of crossover being used (exp: exponential; bin: binomial).

A strategy that works out to be the best for a given problem may not work well when applied to a different problem. Also, the strategy and the key parameters to be adopted for a problem are to be determined by trial and error. However, strategy-7 (DE/rand/1/bin) appears to be the most successful and the most widely used strategy. In all, three factors control evolution under DE, the population size NP, the weight applied to the random differential F and the crossover constant CR

### 3. MATHEMATICAL MODELING AND OPTIMIZATION OF BOOSTER TRANSFORMERS

Most engineering optimization problems include constraints. Traditional evolutionary algorithms have included constraints as the simple bounds on the variables. However, recent reports have begun to address the general constrained optimization problems.

#### 3.1. Constrained optimization problems

Let us consider nonlinear constrained optimization problems as follows:

$$\begin{aligned}
 & \min_{\mathbf{x}} f(\mathbf{x}) \\
 & \text{st } g_i(\mathbf{x}) \leq 0, \quad i = 1, \dots, q \\
 & \quad h_j(\mathbf{x}) = 0, \quad j = q + 1, \dots, m \\
 & \quad \mathbf{x}^{\text{LB}} \leq \mathbf{x} \leq \mathbf{x}^{\text{UB}}
 \end{aligned} \tag{6}$$

where  $h_j(\mathbf{x})$  and  $g_i(\mathbf{x})$  stand for the equality and inequality constraints, and the decision parameter vector  $\mathbf{x}$  is defined on the large search space where  $\mathbf{x}^{\text{LB}}$  and  $\mathbf{x}^{\text{UB}}$  are the lower and upper bound of the decision parameters, respectively.

The difficulty of using evolutionary algorithms in the con-strained optimization is that the evolutionary operators used to manipulate the individuals of the population often produce infeasible solutions. Penalty function methods are one of the most popular techniques in EAs to handle constraints (Michalewicz and Schoenauer, 1996) [23,24]. Such techniques transform a constrained problem into an unconstrained problem by penalizing infeasible solutions. However, the main limitation of penalty functions is the degree to which each constraint is penalized.

Such penalty functions tend to be ill behaved near the boundary of the feasible domain where the optimum points normally lie.

In order to find the global optimum design of a booster transformer, DE in conjunction with the penalty function approach technique is used, focused on the minimization of the cost of the booster transformer.

$$\min_{\mathbf{x}} \sum_{j=1}^2 c_j \cdot f_j(\mathbf{x}) \quad (7)$$

where  $c_1$  is the winding unit cost (€/kg),  $f_1$  is the winding weight (kg),  $c_2$  is the magnetic material unit cost (€/kg),  $f_2$  is the magnetic material weight (kg), and  $\mathbf{x}$  is the vector of the five design variables, namely the width winding ( $a$ ), the diameter of core leg ( $D$ ), the winding height ( $b$ ), the current density of winding ( $g$ ) and the magnetic flux density ( $B$ ) [22, 25, 26].

The minimization of the cost of the booster transformer is subject to the constraints:

$$S - S_N \leq 0; P_{CU} - P_{CUN} \leq 0; P_{FE} - P_{FEN} \leq 0; Z_{TOT} - Z_{TOTN} \leq 0 \quad (8)$$

where:  $S$  is designed booster transformer rating (kVA),  $S_N$  is booster transformer nominal rating (kVA),  $P_{FE}$  is designed no-load losses (W),  $P_{CU}$  is designed load losses (W),  $Z_{TOT}$  is designed impedance of booster transformer secondary side (Ohms),  $P_{FEN}$  is guaranteed no-load losses (W),  $P_{CUN}$  is guaranteed load losses (W) and  $Z_{TOTN}$  is guaranteed impedance of booster transformer secondary side (Ohms).

The single objective Differential Evolution optimization algorithm with penalty function approach has been applied. Accordingly, the objective function for the model is:

$$f(x_2, x_3, x_5) = (2.10 \cdot 10^4 \cdot x_5 + 1.60 \cdot 10^5 \cdot x_3 + 2.04 \cdot 10^3) \cdot x_2^2 + 1.38 \cdot x_2^3 + (5.10 \cdot 10^5 \cdot x_2 + 1.20 \cdot 10^6 \cdot x_3 + 1.22 \cdot 10^4) \cdot x_3 \cdot x_5 \quad (9)$$

The inequality constraints should be modified to the less or equal format. The constraints of the analyzed mathematical model are entered as follows: Constraint 10 match to booster transformer nominal rating, Constraint 11 match to guaranteed load losses, Constraint 12 match to guaranteed no-load losses and Constraint 13 guaranteed impedance of booster transformer secondary side. Constants in front of decision variables have been taken from the Fig.1 and reference [10,14].

$$208.6 \cdot x_1 \cdot x_2^2 \cdot x_3 \cdot x_4 \cdot x_5 \cdot 10^3 - 253 \leq 0 \quad (10)$$

$$(2.12 \cdot 10^{-7} \cdot x_2 + 4.06 \cdot 10^{-7} \cdot x_3 + 4.53 \cdot 10^{-9}) \cdot x_3 \cdot x_4^2 \cdot x_5 - 2150 \leq 0 \quad (11)$$

$$(-0.30 \cdot x_1^2 + 0.85 \cdot x_1 - 0.04) \cdot$$

$$\left( (2.57 \cdot 10^4 \cdot x_5 + 1.6 \cdot 10^5 \cdot x_3 + 2.04 \cdot 10^3) \cdot x_2^2 + 1.33 \cdot x_2^3 \right) \cdot 0.25 - 95 \leq 0 \quad (12)$$

$$\left(0.02 \cdot x_2 + 0.01 \cdot x_2 \cdot x_3 + 0.04 \cdot x_3 + 1.13 \cdot x_3^2 + 1.4 \cdot 10^{-4}\right) \cdot 208.6 \cdot 0.012 \cdot x_3 \cdot x_4 / x_1 \cdot x_2^2 - 0.09 \leq 0 \quad (13)$$

These values are multiplied by a penalty co-efficient, which is then added to the objective function to continue the process of optimization.

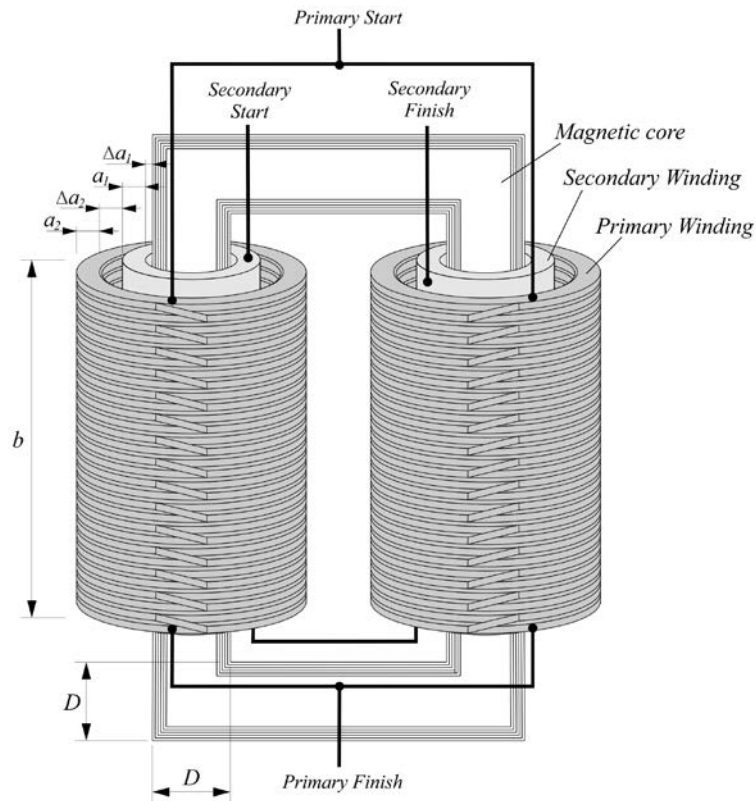

Fig. 1. Active part of a booster transformer with main dimensions

The output figures in Table 1 are given for the analyzed mathematical model after the successful completion.

Table 1.

Parameter	X <sub>1</sub>	X <sub>2</sub>	X <sub>3</sub>	X <sub>4</sub>	X <sub>5</sub>
Value	0.21011	0.24645	0.01727	2.56086	0.62025

The parameters  $X_1$ ,  $X_2$ ,  $X_3$ ,  $X_4$ ,  $X_5$  match respectively to the magnetic flux density ( $B$ ), the diameter of core leg ( $D$ ), the width of secondary winding ( $a$ ), the current density of secondary winding ( $g$ ) and the core window height ( $b$ ).

Comparative results of the analyzed mathematical model with different optimization approaches are shown in Table 2 [10].

Table 2.

	$B$	$g$	$D$	$a$	$b$	Cost of Active part
DE Algorithm	0.21	2.56	246	17	620	3685
Lag.New.R.[10]	0.23	2.78	248	18	610	3982

#### 4. EXPERIMENTS AND RESULTS

For confirming the specifications and performances of a booster transformer it has to go through a number of testing procedures. Some tests are done at a transformer manufacturer premises before delivering the transformer. Transformer manufacturers perform two main types of transformer testing – type test of transformer and routine test of transformer. Guaranteed manufactured values are shown in Table 3.

Table 3.

Rating: 200 (Amps)	Cooled: ONAN		Phase: Single		Frequency: 50 (Hz)
Primary:	Amps.: 200		Connected: Parallel		Taps: -
Secondary:	Amps.: 200		Connected: Series		
Standard:	IEC 60076(VR-1RIM-B)		Rise: 60/65 (°C)	Design no.: LT 2019/01	
17.35 Volts / Turn	Core	Leg	Core circle (mm)	246	Guarantee at
Section	240 x 228	228 x 240	Centres (mm)	400	Rating 200 (Amps)
Area (cm <sup>2</sup> )	431.8	440.9	Height of window (mm)	620	Voltage / (V) 75 (°C)
B(T)	0.2125	0.2081	Design no.	LT 2019/01	Loss P <sub>Fe</sub> = 95 (W)
Total loss (Fe) (W)	115		Quality of iron	30M5	P <sub>Co</sub> = 2150 (W)
Total weight (Fe) (kg)	816		Layer	2	Z (Ohms) = 0.09 approx.

To successfully pass the impulse test, we used a cylindrical coil on the primary winding and a foil coil on the second. The first approximately 30% turns with 3 layers of nomex paper and the interlayer insulation with one paper plus(DDP-Diamond Dotted transformer Insulation Paper) were reinforced on the primary winding. Approximately 30% of the windings on the secondary winding were reinforced with a single paper plus(DDP-Diamond Dotted transformer Insulation Paper).

4.1. Tests at independent accredited laboratory

DC resistance measurement ( $I_{DC}=30A$ )

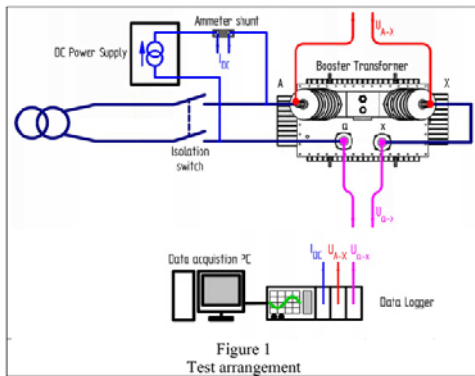

Winding	Resistance [mΩ]	Temperature [°C]
A – X	21.18513	23.3
a – x	15.81955	23.3
Short-circuit	37.2338	23.5

Impedance measurement ( $I_{AC}=200A$ )

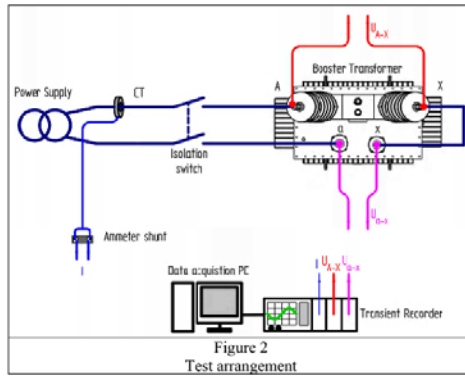

Winding	Impedance [mΩ]	Resistance [mΩ]	Reactance [mΩ]
A – X	60.87	19.93	57.51
a – x	33.74	18.94	27.92

Short-circuit impedance measurement ( $I_{AC}=200A$ )

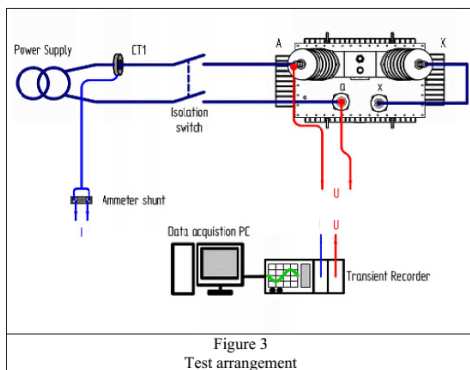

T=23.5°C

Winding	Impedance [mΩ]	Resistance [mΩ]	Reactance [mΩ]
Short-circuit	94.45	39.7056	85.6950
Short-circuit (75°C)	98.04	47.6160	85.69

Temperature-rise test (Item 4.2.1)

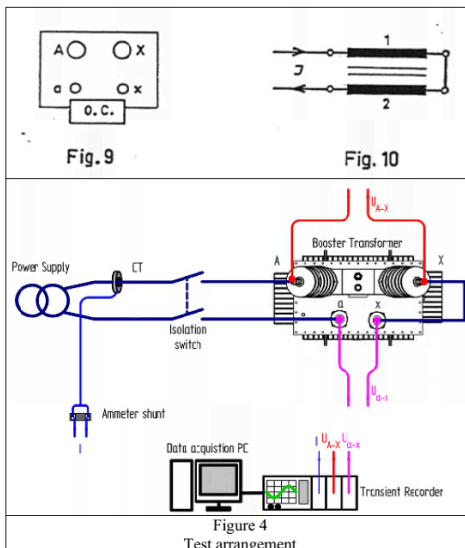
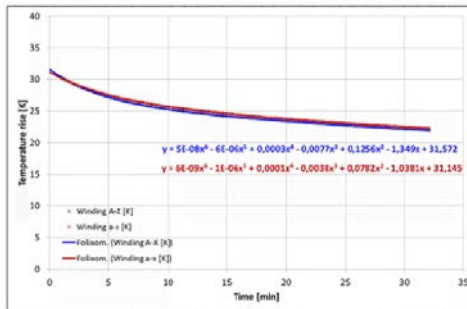
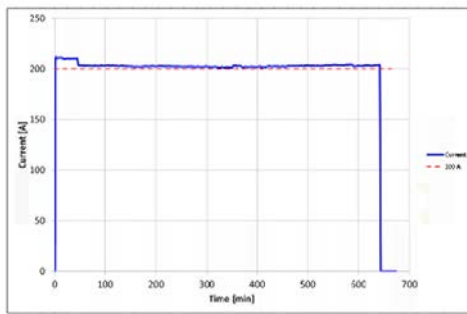
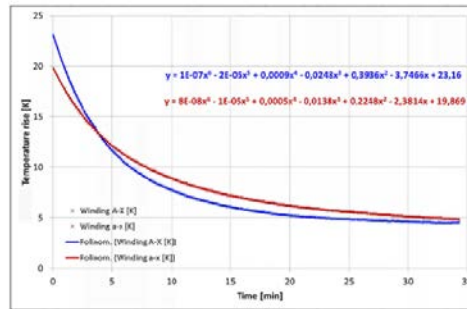
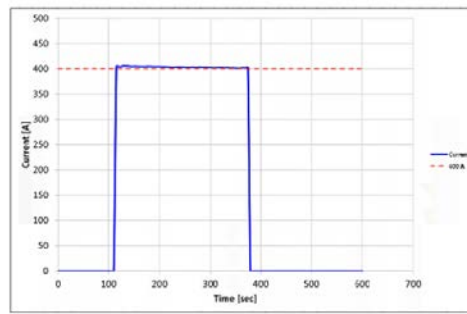

Fig. 2. Routine Test and Temperature-rise Test arrangement

Temperature-rise test (200A – continuous)



Temperature-rise test (400A – 5 min)



Temperature-rise test (700A – 1 min)

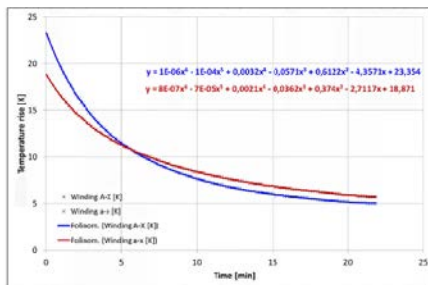
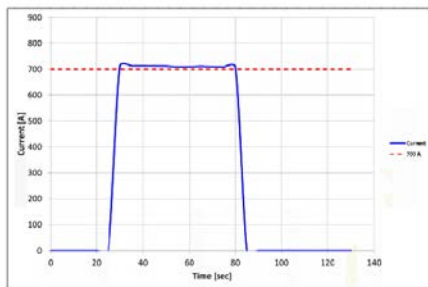

Temperature-rise test (200A – continuous)

Measured part	Temperature rise [K]
Top oil	24.2
Average winding (A – X)	31.6
Average winding (a – x)	31.2
Ambient temperature	24.5 °C

Temperature-rise test (400A – 5 min)

Measured part	Temperature rise [K]
Top oil	6.6
Average winding (A – X)	23.2
Average winding (a – x)	19.9
Ambient temperature	23.9 °C

Temperature-rise test (700A – 1 min)

Measured part	Temperature rise [K]
Top oil	6.1
Average winding (A – X)	23.4
Average winding (a – x)	18.9
Ambient temperature	24.0 °C

Fig. 3. Temperature-rise Test

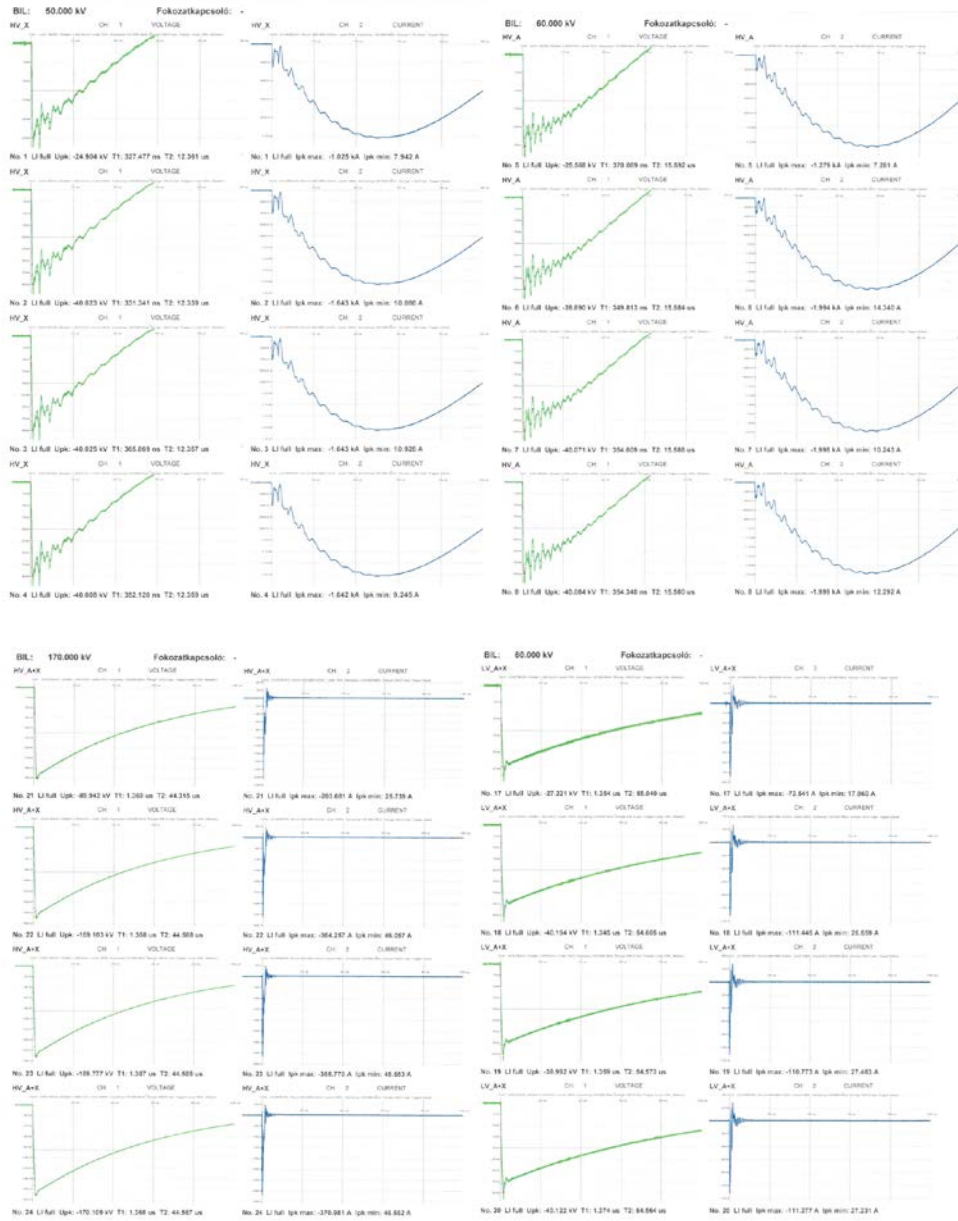

Fig. 4. Impulse Test

## 5. CONCLUSION

In this paper, one of the recently proposed heuristic algorithms DE is used to solve the optimal cost problem with equality and inequality constraints in booster transformers. In this case, the minimization of active part cost is considered as objective function. The results proved the robustness and superiority of the DE approach to solve the optimal cost of an active part of a booster transformer. Comparative results of the analyzed mathematical model with different optimization approach is shown in Table 2. The effectiveness of the DE algorithm is demonstrated and the observations revealed that the DE gives an optimal solution with less number of generations and requires less computation time. Parameters used in DE: Number of population points (NP) = 20, Maximum Number of Iterations = 100, DE Key Parameters: Scaling Factor (F) = 0.4, Cross-over Constant (CR) = 0.9. Best Strategy is Strategy DE/rand/1/bin. Minimum constraint violation (CV): 0.0000E+000. Minimum objective value with min CV: 3.685230E+003. Minimum time taken: 20 ms.

Moreover, this approach is easy to implement and its computational cost is relatively low. Using the output data from the application of the DE algorithm due to the reduced values, for successful handling of routine tests (impulse and temperature rise test), we have used materials from the most famous manufacturers in the arrangement of insulation (Diamond Dotted Transformer Insulation Paper made of electrical insulating paper with diamond-shape epoxy resin dotted in both sides, Transformerboard, Paper and Component solutions...). Impulse, Temperature rise and Temperature rise test with overloading at the request of the final buyer for railways. Verification of results is confirmed with test in an independent accredited laboratory.



*Fig. 5. Manufactured Booster Transformer (200 Amps) subject to research*

## ACKNOWLEDGMENT

The authors would like to thank the LEMI TRAF0 JSC, Pernik, Republic of Bulgaria to manufacture the booster transformer and independent accredited laboratory VEIKI-VNL Kft, Budapest, Hungary to test the booster transformer.

## REFERENCES

- [1] A. Vasan, Optimization Using Differential Evolution. *Water Resources Research Report. Book 22. Department of Civil and Environmental Engineering*, The University of Western Ontario, Publication Date 7-2008.
- [2] A. Zamuda, J. Brest, B. Bošković, V. Žumer. Differential Evolution with Self-adaptation and Local Search for Constrained Multi-Objective Optimization. *IEEE Congress on Evolutionary Computation (CEC)*, 2009, pp. 195-202.
- [3] J. Brest, A. Zamuda, B. Bošković, V. Žumer. Dynamic Optimization using Self-Adaptive Differential Evolution. *IEEE Congress on Evolution. Computation(CEC)*, Trondheim, Norway, 2009, pp. 415-422.
- [4] DE Homepage. <http://www.icsi.berkeley.edu/~storn/code.html>
- [5] Onwubolu, G. C., and Babu, B. V. *New Optimization Techniques in Engineering*. Springer-Verlag, Germany, 2004.
- [6] P.V. Kenneth., S.M. Rainer. Differential evolution - A simple evolution strategy for fast optimization. *Dr. Dobb's Journal*, 1997, 22, 18-24 and 78.
- [7] P.V. Kenneth., S.M. Rainer., L.A. Jouni. Differential evolution: A practical approach to global optimization. Springer-Verlag, Berlin, Heidelberg, 2005.
- [8] B.V. Babu, M. Mathew, L. Jehan. Differential Evolution for Multi-Objective Optimization. *Chemical Engineering Department B.I.T.S. Pilani*, India, 2005.
- [9] E.I. Amoiralis, P.S. Georgilakis, M.A. Tsili. Design optimization of distribution transformers based on mixed integer programming methodology. Technical University of Athens, Greece, 2008.
- [10] R. Salkoski. Selection of an optimal variant of 3-phase transformers with round and rectangular section of the magnetic core from aspect of minimum production costs. *Master Thesis, Electro technical University in Skopje*, 2000.
- [11] Mezura and Montes.: E. Laboratorio NI Avanzada, Rébsamen 80, Centro, Xalapa, Veracruz 91090, Mexico, Velazquez-Reyes, J., Coello Coello, C.A. Modified Differential Evolution for Constrained Optimization, *Conference Publications, Evolutionary Computation, CEC*, 2006, pp 25 – 32.

- [12] U.K. Chakraborty (Ed.). *Advances in Differential Evolution, Mathematics & Computer Science* Department, University of Missouri, St. Louis, USA, Springer-Verlag Berlin Heidelberg, 2008.
- [13] J. Rönkkönen, S., Kukkonen, K. V. Price.: Real-parameter optimization with differential evolution. *Proc. IEEE Congr. Evolution. Comput.*, Sep. 2005, pp. 506–513, Edinburgh, Scotland (2005).
- [14] R. Salkoski, I. Chorbev. Design optimization of distribution transformers based on Differential Evolution Algorithms. *ICT Innovations 2012*, ISSN 1857-7288, Ohrid, 2012, pp.35-44.
- [15] R. Salkoski, Design and tests of high voltage reactors. The Fourth Conference MAKO CIGRE, A2-08, September, Ohrid 2004.
- [16] R. Salkoski, Arc Suppression Coils with adjustable gap. The First Conference MAKO CIGRE, STK 12, P12-01, Struga, 1996.
- [17] S. Wang, Y. Duan, W. Shu, D. Xie, Y. Hu, Z. Guo. Differential Evolution with Elite Mutation Strategy. *J. of Comput. Inform. Sys.* 9:3, 2013, pp.855-862.
- [18] F.S. Lobato, R. Gedraite, S. Neuro. Solution of Flow Shop Problems using the Differential Evolution Algorithm. *EngOpt 2012-3rd ICEO*, Rio de Janeiro, Brazil, 01-05, 2012.
- [19] S.K. Morya, H. Singh. Reactive Power Optimization Using Differential Evolution Algorithm. *IJETT-Volume 4 Issue 9*, 2013.
- [20] A. Lotfi, M. Faridi. Design Optimization of Gapped-Core Shunt Reactors. *IEEE Transactions on Magnetics. Vol. 48, No. 4*, 2012.
- [21] A. Lotfi, E. Rahimpour. Optimum design of core blocks and analyzing the fringing effect in shunt reactors with distributed gapped-core. *ELSEVIER, Electric Power Systems Research* 101, 2013, pp.63-70.
- [22] R. Salkoski, “Heuristic algorithm for multicriterial optimization of power objects”, *PhD Thesis*, University” SS. Cyril and Methodius” FEIT, Skopje, R. Macedonia (2018)
- [23] Michalewicz, Z. and M. Schoenauer, ‘Evolutionary Algorithms for Constrained Parameter Optimization Problems, *Evolutionary Computation*, 4, 1 (1996).
- [24] Michalewicz, Z., *Genetic Algorithms + Data Structures = Evolution Programs* Springer-Verlag Berlin Heidelberg, New York, USA (1996).
- [25] Rasim Salkoski, Ivan Chorbev.: Influence of Weighting factor and Crossover constant on the behaviour of Differential Evolution Algorithms with a Penalty Function approach, September 2018 *ICT Innovations 2018*, Web Proceedings

- [26] Rasim Salkoski, Ivan Chorbev. Design optimization of power objects based on Constrained non-linear minimization, Genetic algorithms, Particle swarm optimization algorithms and Differential Evolution Algorithms, *International Journal on Information Technologies and Security*, 2014, Sofia, ISSN 1313-8251, pp. 21 – 30
- [27] Babu, B.V., Mubeen, J.H.S. and Chakole, P.G., 2005, Multiobjective Optimization Using Differential Evolution, *TechGenesis-The Journal of Information Technology*, 2, 4-12.
- [28] Angira, R. and A.Santosh, “Optimization of Dynamic Systems”: A Trigonometric Differential Evolution Approach, *Computers and Chemical Engineering*, 31, 1055(2007).
- [29] Babu, B.V. and Angira, R., 2006, Modified Differential Evolution (MDE) for Optimization of Non-Linear Chemical Processes, *Computers & Chemical Engineering*, 30, 989-1002.
- [30] Z.X. Cai and Y. Wang, A multi-objective optimization-based evolutionary algorithm for constrained optimization, *IEEE Trans. Evol. Comput.*, 10(6), 658-675, 2006
- [31] Schwefel, H.P., *Evolution and Optimal Seeking*, John Wiley and Sons Inc., New York,(1995)

#### ***Information about the authors:***

**Rasim Salkoski** - Teaching and research assistant at the University of Information Science and Technology Ohrid from 2009. He completed his PhD studies at the Faculty of Electrical Engineering FEIT in Skopje in 2018; participated in more than 16 scientific conferences; research interests include combinatorial optimization, heuristic algorithms, constraint programming and their application in the field of electrical energy and networks.

**Ivan Chorbev** – He was born in 1980 in Ohrid, R. of Macedonia. He earned his bachelor and master degrees at the Faculty of Electrical Engineering in Skopje, R. of Macedonia in 2004 and 2006. He completed his PhD studies at the Faculty of Electrical Engineering and Information Technologies in Skopje in 2009. The fields of his research interests include combinatorial optimization, heuristic algorithms, constraint programming, web development technologies, software testing, application of computer science in medicine and telemedicine, medical expert systems, knowledge extraction, machine learning

**Manuscript received on 9 April 2020**