

Volume 9  
Issue 1  
July 2020

ISSN - 1857 - 839X

# SJCE

SCIENTIFIC  
JOURNAL  
OF CIVIL  
ENGINEERING



### FOUNDER AND PUBLISHER

Faculty of Civil Engineering  
Partizanski odredi 24, 1000  
Skopje, N. Macedonia

### PRINT

This Journal is printed in Printing  
House "Van Gog", Skopje

### EDITORIAL OFFICE

Faculty of Civil Engineering  
Partizanski odredi 24, 1000  
Skopje, N. Macedonia  
tel. +389 2 3116 066  
fax. +389 2 3118 834  
prodekan.nauka@gf.ukim.edu.mk

### EDITOR IN CHIEF

Assoc. Prof. PhD **Marijana  
Lazarevska**  
University "Ss. Cyril and  
Methodius"  
Faculty of Civil Engineering  
Partizanski odredi 24, 1000  
Skopje, N. Macedonia  
marijana@gf.ukim.edu.mk

### EDITORIAL ADVISORY BOARD

Prof. PhD **Elena Dumova-  
Jovanoska**  
University "Ss. Cyril and  
Methodius", Skopje, N. Macedonia

Assist. Prof. PhD **Zlatko  
Bogdanovski**  
University "Ss. Cyril and  
Methodius", Skopje, N. Macedonia

### TECHNICAL EDITORS

MSc **Milica Jovanoska**  
Assistant, University "Ss. Cyril and  
Methodius", Skopje, N. Macedonia

MSc **Kristina Milkova**  
Assistant, University "Ss. Cyril and  
Methodius", Skopje, N. Macedonia

MSc **Riste Volcev**  
Assistant, University "Ss. Cyril and  
Methodius", Skopje, N. Macedonia

ISSN: 1857-839X

### EDITORIAL BOARD

Em.O.Univ.Prof. Dipl.-Ing.  
Dr.h.c.mult. Dr.techn. **Heinz  
Brandl** Vienna University of  
Technology, Austria

Prof. PhD **Zalika Crepinsek**  
University of Ljubljana, Slovenia

Prof. PhD **Elena Dumova-  
Jovanoska**  
University "Ss. Cyril and  
Methodius", Skopje, N. Macedonia

Prof. PhD **Ibrahim Gurer**,  
Gazi University, Turkey

Prof. PhD **Miodrag Jovanovic**  
University of Belgrade, R Serbia

Prof. PhD **Milorad Jovanovski**  
University "Ss. Cyril and  
Methodius", Skopje, N. Macedonia

Prof. PhD **Milos Knezevic**  
University of Montenegro

PhD, PE, CE **Davorin Kolic**  
ITA Croatia

Prof. PhD **Stjepan Lakusic**  
University of Zagreb, Croatia

Assoc. Prof. PhD **Jakob Likar**  
University of Ljubljana, Slovenia

Prof. PhD **Ljupco Lazarov**  
University "Ss. Cyril and  
Methodius", Skopje, N. Macedonia

Univ.dipl.ing.gradb. **Viktor  
Markelj**, University of Maribor,  
Slovenia

**Marc Morell**  
Institute des Sciences de  
l'Ingénieur de Montpellier, France

Prof. PhD **Darko Moslavac**  
University "Ss. Cyril and  
Methodius", Skopje, N. Macedonia

Prof. PhD **Cvetanka Popovska**  
University "Ss. Cyril and  
Methodius", Skopje, N. Macedonia

Prof. PhD **Todorka Samardzioska**  
University "Ss. Cyril and  
Methodius", Skopje, N. Macedonia

Prof. PhD **Biljana Scepanovic**  
University of Montenegro

Prof. PhD **Zlatko Srbinoski**  
University "Ss. Cyril and  
Methodius", Skopje, N. Macedonia

Prof. Dr.ir. **J.C. Walraven**  
Delft University of Technology,  
Netherlands

### COVER DESIGN:

Prof. PhD **Mitko Hadzi Pulja**  
MSc **Betim Zeqiri**  
Faculty of Architecture  
University "Ss. Cyril and  
Methodius", Skopje, N. Macedonia

### ORDERING INFO

**SJCE** is published bi-annually.  
All articles published in the journal  
have been reviewed.  
Edition: 100 copies

### SUBSCRIPTIONS

Price of a single copy:  
for Macedonia (500 den);  
for abroad (10 EUR + shipping  
cost).

### BANKING DETAILS (NORTH MACEDONIA)

Narodna banka na RNM  
Account number:  
160010421978815  
Prihodno konto 723219,  
Programa 41

### BANKING DETAILS (INTERNATIONAL)

Correspond bank details:  
Deutsche Bundesbank Zentrale  
Address: Wilhelm Epstein Strasse  
14 Frankfurt am Main, Germany  
SWIFT BIC: MARK DE FF  
Bank details:  
National Bank of the RNM  
Address: Kompleks banki bb 1000  
Skopje North Macedonia  
SWIFT BIC:NB RM MK 2X  
IBAN: MK 07 1007 0100 0036 254  
Name: Gradezen fakultet Skopje

## CONTENTS

---

M. Cvetkovska	
18TH SYMPOSIUM OF MASE	5
M. Docevska, G. Markovski	
INFLUENCE OF CONCRETE AGE ON A COMPOSITE CONCRETE SECTION BEHAVIOR	7
R. Hajdin	
EXISTING BRIDGES – BURDEN OR OPPORTUNITY?	13
H. Pasternak, T. Bretschneider	
INSPECTION AND MAINTENANCE OF STRUCTURES OF LARGE FAILURE CONSEQUENCE CLASS - EXAMPLE TROPICAL ISLAND	27
P. L. Popovic	
AVOIDING MISTAKES DURING ASSESSMENT, DESIGN AND CONSTRUCTION OF STRUCTURAL REPAIRS	35
P. L. Popovic, D. Vla	
ASSESSMENT AND REPAIR OF EXTERIOR FACADES	43
V. Shendova	
SEISMIC RETROFITTING OF STRUCTURES, HISTORIC BUILDINGS AND MONUMENTS - IZIIS' APPROACH	53
B. Stevanovic	
REHABILITATION AND RECONSTRUCTION OF SOME HISTORICAL STRUCTURES IN SERBIA	65
S. Bogoevska, D. Nakov, T. Arangjelovski, G. Markovski	
MONITORING BASED STRUCTURAL IDENTIFICATION OF TWO RAILWAY BRIDGES	77
Z. Markovic, J. Dobric, N. Gluhovic	
COMPARISON OF WIND ACTIONS ACCORDING TO EUROCODE AND PREVIOUS REGULATIONS	83
S. Mikarovska, D. Popovski, M. Partikov	
ANALYSIS OF RESISTANCE AND STABILITY OF CASTELLATED COMPOSITE BEAM FOR DIFFERENT NUMBER OF SHEAR CONNECTORS	93

D. Popovski, M. Partikov, D. Denkovski	
PULL-OUT TEST FOR MECHANICAL ANCHORS	99
I. Petrovska, L. Dimov	
AUTOMATIC CLASSIFICATION OF LAND COVER USING MULTISPECTRAL SATELLITE IMAGERY: VALLEY OF RIVER TRESKA, MACEDONIA	105
S. Stankovski, S. Churilov	
DYNAMIC ANALYSIS OF BELL TOWER WITH BELL FORCES	111

**Stefanija Mikarovska**

MSc civil engineer  
mikarce.st@gmail.com

**Denis Popovski**

PhD, Associate Professor  
University “Ss. Cyril and Methodius”  
Faculty of Civil Engineering – Skopje  
popovski@gf.ukim.edu.mk

**Mile Partikov**

PhD, Assistant Professor  
University “Ss. Cyril and Methodius”  
Faculty of Civil Engineering – Skopje  
partikov@gf.ukim.edu.mk

## **ANALYSIS OF RESISTANCE AND STABILITY OF CASTELLATED COMPOSITE BEAM FOR DIFFERENT NUMBER OF SHEAR CONNECTORS**

One castellated and seven composite castellated beams are modeled using the software package SAP2000. The composite beams are modeled using link elements as shear connectors with stiffness of 100 kN/mm. For the composite models, one beam with 52 links, four beams with 26 link and two beams with 15 links are adopted with different positioning: above the openings, above the web-posts and uniformly along the beam. It was determined that the increase of shear connectors leads to increase of normal stresses in the corners of the first opening, where in comparison with castellated beam there is 30 % and 15 % rise for 52 links and 15 links above openings correspondingly for uniform load of 39 kN/m'. There is also a difference of 5 % between the stresses for links above openings and above web-posts, where the favorable position is that across the openings. According to the previous, the most commending beam will be with fewer shear connectors positioned above the openings. Therefore it can be assumed that it is best to design the castellated composite beam with partial shear connection, otherwise it would have to ensure full web near supports or increase the stiffness of the bottom part of the beam – concluding an optimized asymmetric section.

**Keywords:** castellated beam, composite beam, partial shear connection, local stability

### **1. INTRODUCTION**

The stiffness of an I or H steel beam section can be increased by two means: with composite action; and cutting the web along the longitudinal axis in a zig zag or other pattern, and welding the two parts together in a way to produce a higher section where the stiffness can be increased by 40 % (Figure 1.) Depending on the cutting pattern, numerous types of beams can be fabricated: *castellated beam*, cellular beam, beam with sinusoidal and elongated openings. As the most optimal

geometry, according minimal waste material and one cutting procedure in production, for this research castellated beam is used.

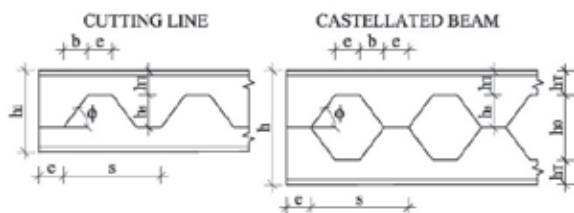

Figure 1. Castellated beam and cutting line.

In some instances, the choice for this type of beam may not be obvious, like in structures where there is substantial concentrated loading (bridges) or for heavy loaded continuous beams where reinforcement is needed around the critical openings, thus increasing the production price. The structural advantage of this type of beam is seen at long span structures where the design is governed by serviceability limit state (SLS). As for functional advantage, the passing of installation through openings and easier installation of secondary structural systems (like ceiling system) provide optimal exploitation of space which can be significant for multistory buildings.

Beside the mentioned advantages, the openings disrupt the stress flow along the web where stress localization occurs at the edges of the openings resulting in additional modes of failure. Experimental and finite element studies on castellated beams have reported six main different modes of failure (Kerdal and Nethercot (1984)): (1) flexural mechanism, (2) 'Vierendeel' or shear mechanism, (3) rupture of welded joints, (4) lateral torsional buckling and web-post buckling due to (5) shear or (6) compression.

Vierendeel mechanism is associated with high shear forces where plastic hinges are formed at the edges of the web openings due to secondary bending moments which are result from the action of shear force in the tee-sections over the horizontal length of the opening ( $l_{eff} = e$ ). In oppose of non-composite castellated beam, the composite action increases the Vierendeel resistance for  $M_{vc}/l_{eff}$  where it depends on the number of shear connectors above the opening, the uplift resistance and length of the opening (Lawson et al. (2013)), figure 2. The composite action also changes the position of the neutral elastic and plastic axis - moving it toward the concrete slab, which results in decrease of the horizontal shear force ( $V_{h,Ed}$ ) and bending moment ( $M_{h,Ed}$ ) in the narrowest part of the web-post. Because

the web-post buckles under high horizontal shear force, the redistribution of internal forces is in favor.

In general, the composite action has positive impact on the resistance and stability of the castellated beam and is closely associated with the number, resistance and position of the shear connectors. Despite the numerous studies, there is very little research on the stress distribution around the openings for different number of shear connectors and their configuration above the openings and web-posts. Most of the provided research gives a correlation of the resistance and stability to the opening geometry and concrete strength.

Sheehan et al. (2016) [7] conducted an experiment on two unpropped asymmetric composite cellular beam for determining the minimal shear connection degree. They concluded that the provided minimal shear connection degree requirement according EN1994-1-1 for composite steel beams cannot be used for this type of beams.

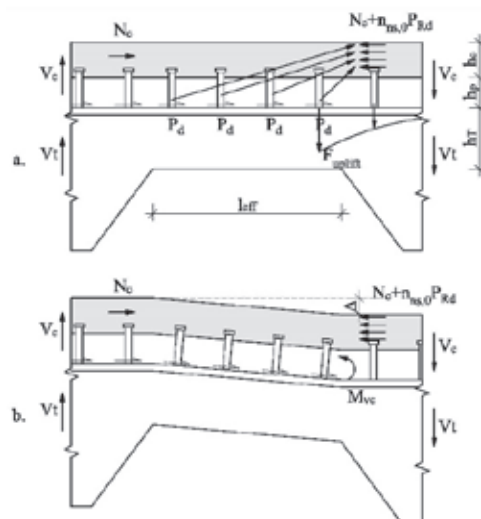

Figure 2. Vierendeel bending and Vierendeel resistance moment due to composite action.

The obtained minimal degree was 36 %, almost half of the calculated minimal degree according the analytical relations in accordance to EN. Aggelopoulos et al. (2018) [1] also conducted research for this specific topic. They provided relations for calculating the minimal shear degree for propped and unpropped composite beams with the conclusion that if the opening diameters for symmetrical and asymmetrical beams exceeds 60 % of the height, the minimal shear degree can be relaxed.

The aim of this research is to define the difference in stress distribution for different

number of shear connectors and configuration along the beam, as for the optimal position and correlation to the different modes of failure. Also, analytical computation is made based on the existing manuals (SCI publication P355, Lawson and Hicks (2011) [6]) and working documents (Lawson et al. (2006), [5]) according to EN 1994-1-1 for comparison with the numerical results

## 2. NUMERICAL ANALYSIS

In the software package SAP2000 seven composite symmetrical castellated beams are modelled using finite elements for the steel and concrete section and link elements for the shear connectors. All the models are geometrically identical, except for the number of shear connectors. The geometric recommendations (empirical relations) for balanced failure between modes that are given in literature are taken in consideration while defining the geometry.

### 2.1 MATHEMATICAL MODEL

IPE550 is adopted for the base steel beam and its cut in a pattern that a castellated beam with full height of 750 mm are made.

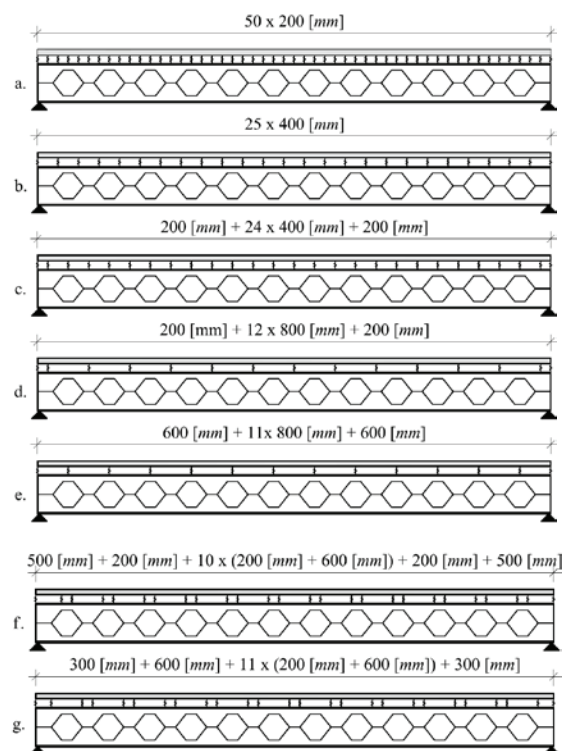

Figure 3. Seven composite castellated beams with different number of shear connections – links (52, 26 and 15 links)

The height ( $h_0$ ) and width of the openings ( $2xb+e$ ) are taken as 250 mm and

$2x200+200 = 600$  mm, while the width ( $b_{sl}$ ) and thickness ( $h_{sl}$ ) of the slab are 260 mm and 62 mm. The height of the shear connectors is 86 mm in length and the same are modelled as link elements with stiffness 100 kN/mm, meaning all the models have full composite action. The beams are modeled as simple supported spanning 10 m (Figure 3). For the steel S235 grade is used, while for the concrete slab class C30/37 with  $\sigma$ - $\epsilon$  curve according EN for nonlinear analysis.

The concrete slab and steel beam are modeled with 2D shell elements with discretization of  $50x6500$  mm and  $50x50$  mm (Figure 4). The discretization for the steel beam is made denser because the main goal of this research is the effect of composite action on the structural behavior of the steel beam. Because of the high concentration of stress in the corners and the openings in the web, despite the ratio  $h/L$ , *thick shell* elements are used for the web, as for the flanges and concrete slab *thin shell* elements. For the shear connectors *linear type link* is used with stiffness 100 kN/mm in U1 and U2 direction and fixed in U3 direction.

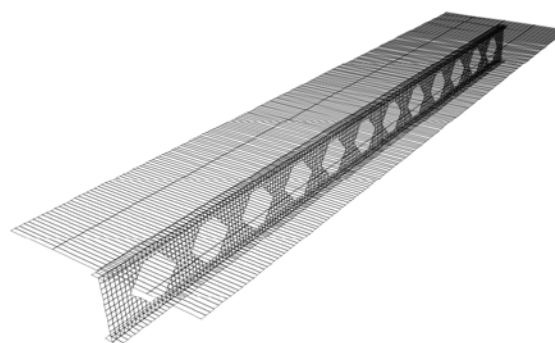

Figure 4. 3D model of composite castellated beam.

To simulate simple support, restraints with free rotation in all directions are assigned to the end joints in line with the beam axis for the non-composite beam, while for the composite beam additional restraints are assigned on the end joints at the support of the slab.

According the analytical calculation, based on the strut model method for web-post buckling analysis, it is expected the castellated beam to first lose its stability under loading of  $15 \text{ kN/m}^2$ , while the other given methods in literature, Aglan and Redwood (1974) [7] and Wang (2016) [9], compute  $24 \text{ kN/m}^2$  and  $23 \text{ kN/m}^2$  critical loading. That is why it is decided to load the slab with uniform load from  $1.0 \text{ kN/m}^2$  to  $15 \text{ kN/m}^2$ .

## 2.2 PROCESSING

Two types of analysis are made: (1) nonlinear static analysis with geometric imperfection ( $P-\delta$ ) – Newton Raphson method; (2) buckling analysis with 6 modes. The first type of analysis is used because of the high stress concentration in the corners of the openings and the additional generated moment in the link elements from the force transfer while the beam is deformed. With this we simulate the Vierendeel bending (figure 2).

## 2.3 POSTPROCESSING

In table 1. the maximum loading and internal forces are given for web-post buckling failure. The critical web-post is the one closest to the

support where the shear forces are largest.

For representing the stress flow along the beam, normal stresses  $S_{11}$  are shown in the following graphical figures along lines 1-1 and 2-2 as given in figure 5. Beside the graphical figures, additional tables are presented, where table 2 correlate the increase and decrease of stresses along the first opening between the non-composite and composite models, given in percentage; and table 3 presents the ratio between the stresses in the beginning and end of the opening for normal and shear stress. In addition to this, a graphical presentation is given in figure 9 and figure 10 for the effect of composite action on the distribution of the maximal  $S_{max}$  and minimal  $S_{min}$  normal stresses along the beam (half span), as of shear stress.

Table 1. Maximum loading and internal forces during failure from local stability of web-post with double curvature

	n	q [kN/m']	[%]	$V_q$ [kN]	$M_q$ [kNm]
Castellated beam	0	96.26	100	385.06	433.19
Composite a)	52	115.18	120	460.71	518.30
Composite b)	26	106.61	111	426.45	479.75
Composite c)	26	109.04	113	436.18	490.70
Composite d)	15	105.57	110	422.27	475.05
Composite e)	15	105.85	110	423.40	476.33
Composite f)	26	108.56	113	434.24	488.52
Composite g)	26	108.71	113	434.82	489.18

n – number of links

q – uniform linear loading

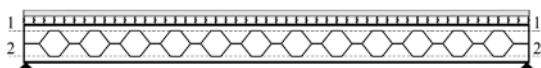

Figure 5. Line 1-1 and 2-2 along the top and bottom of the openings for presenting the stress flow

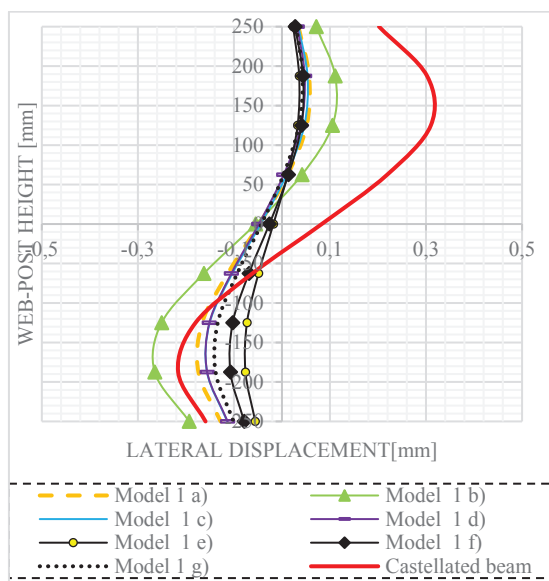

Figure 6. Web-post buckling of first web-post under loading of 15 kN/m<sup>2</sup>

Table 2. Difference in normal  $S_{22}$  and shear  $S_{12}$  stress between non-composite and composite castellated beam for top tee

$l_e$ , [mm]	500*	550	600	650	700*
	% $S_{11}$				
a)	-31.10	-43.01	-126.9	69.89	24.56
b)	-30.71	-42.80	-121.5	57.71	15.88
c)	-25.38	-34.68	-98.73	53.36	17.82
d)	-21.64	-27.58	-65.17	19.62	-1.28
e)	-14.20	-20.26	-60.50	33.50	11.46
f)	-26.25	-36.32	-117.1	78.72	28.92
g)	-32.26	-43.30	-115.8	50.87	10.49
	% $S_{12}$				
a)	-18.18	-12.61	-15.79	1.00	-7.76
b)	-30.71	-42.80	-121.5	57.71	15.88
c)	-19.29	-9.57	-13.92	1.81	-11.1
d)	-11.83	-14.92	-13.51	-12.7	-15.5
e)	-12.49	-3.00	-7.62	3.76	-12.4
f)	-17.64	-12.44	-8.96	10.49	0.17
g)	-16.13	-18.51	-15.34	-13.0	-14.1

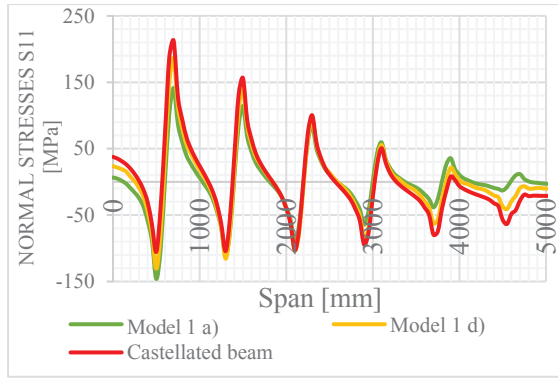

Figure 7. Normal stresses of top tee section along line 1-1 for loading of 15 kN/m<sup>2</sup>

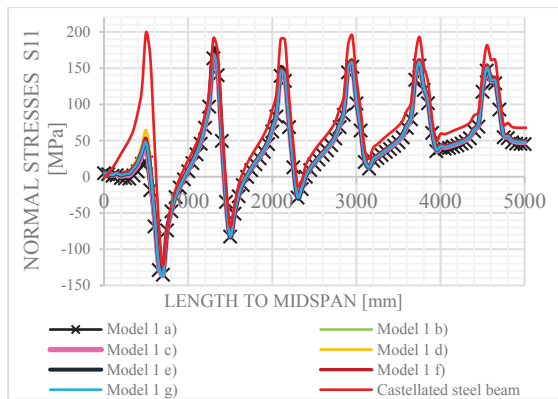

Figure 8. Normal stresses of bottom tee section along line 2-2 for loading of 15 kN/m<sup>2</sup>

Table 3. Percentage ratio for normal  $S_{11}^1/S_{11}^2$  and shear  $S_{12}^1/S_{12}^2$  stress between the beginning (1) and end (2) corners of the opening and ratio between the top and bottom corners  $S_{11}^{top}/S_{11}^{bot}$

	$S_{11}^1/S_{11}^2$	$S_{12}^1/S_{12}^2$	$S_{11}^{top}/S_{11}^{bot}$	
			1	2
	%			
Castell.	-1.64	1.22	-0.99	-0.75
a)	-2.85	1.33	-13.24	-0.67
b)	-2.55	1.23	-6.15	-0.76
c)	-2.50	1.31	-6.32	-0.73
d)	-1.97	1.18	-3.74	-0.91
e)	-2.12	1.22	-4.64	-0.81
f)	-2.92	1.43	-4.73	-0.64
g)	-2.43	1.24	-5.54	-0.79

### 3. RESULTS AND DISCUSSION

Based on the previous given figures we can see that the increase of shear connectors increases the normal stresses at the beginning of the first opening for around 30 % for model a) (52 links) and 14 % for model e) with one link over one opening. At the end of the opening, model f)

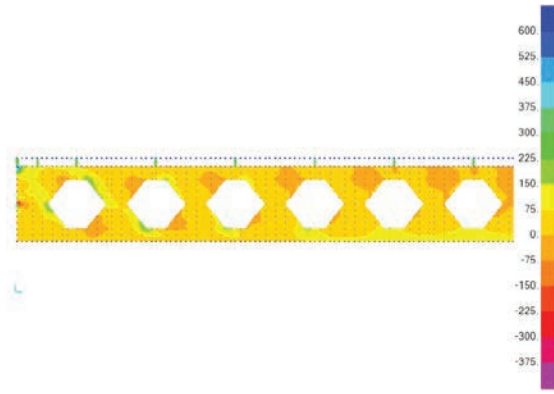

Figure 9. Maximum normal stress  $S_{max}$  of composite beam model e) for loading of 15 kN/m<sup>2</sup>, MPa

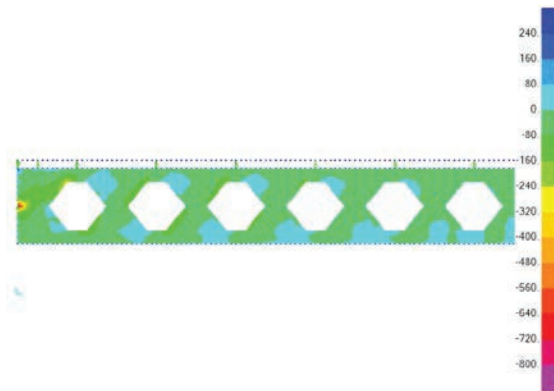

Figure 10. Minimal normal stress  $S_{min}$  of composite beam model e) for loading of 15 kN/m<sup>2</sup>, MPa

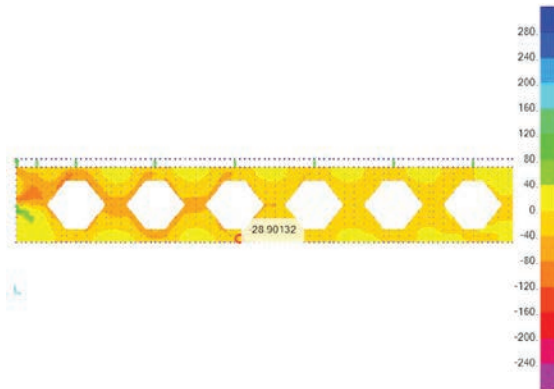

Figure 11. Shear stress  $S_{12}$  of composite beam model e) for loading of 15 kN/m<sup>2</sup>, MPa

with two links over opening has the greatest reduction of normal stress – 29 %. Based on table 2 we can clearly give a conclusion that for composite castellated beams the best option is to distribute less shear connectors with higher bearing resistance than more shear connectors with lower resistance. Also, the models with shear connectors above the opening give around 5 % smaller normal stress and 1 % higher shear stress in the corners than the models with connectors above web-posts.

Another thing to point is the significant difference between the stresses at the beginning and the end of the opening, Table 3 presents that ratio and we can observe that the difference is less for composite beam with 15 links than those of 52 and 26 links. The same goes for the ratio between the stresses of upper and lower Tee section. We can see that the composite action initiates redistribution of the internal forces, resulting in a more stressed upper Tee section. From this fact we can assume that using asymmetrical section where the lower Tee has higher moment of inertia than the upper Tee section, we can facilitate stress reduction in the upper part.

Beside the given above, the increase of shear connectors improves the stability of the web-post, but according to previous research, this failure mode is less likely to occur if the geometry is properly defined in accordance with suggested empirical relations for balanced failure between modes. For 52 links the stability is increased by 20 %, while for 15 links by 10 %.

#### 4. CONCLUSION

Based on the numerical results we can conclude the following:

- (1) Using less shear connectors with higher bearing resistance is more optimal rather than more shear connectors with lower resistance for obtaining full composite action, which results in lesser stress accumulated around the first opening;
- (2) Increasing the number of shear connectors may improve the stability of the web-post against buckling;
- (3) The most favorable position of the shear connectors based on the normal stress is above the opening where there is 5 % increase of resistance against the same number of shear connectors with a position over the web-post;
- (4) Based on the analytical relations and finite element analysis, the most probable optimal design of a castellated beam with composite action is an asymmetric castellated beam that can be formed with larger lower Tee section, or with asymmetrical position of the openings (toward the concrete slab) along the axis.

#### REFERENCE

- [1] Aggelopoulos, E.S., Hanus, F., Lawson, R.M. (2018). Shear connection requirements for composite cellular beams. Proc. Of 12<sup>th</sup> International Conference on Advances in Steel-Concrete Composite Structures (ASCCS 2018), Valencia, Spain, pp. 153-159.
- [2] Directorate-General for Research and Innovation (European Commission), (2006). Large web openings for service integration in composite floors. paper, 14 December 2006.
- [3] European Committee for Standardization, Standard, 2004/1994-1-1/EN, December 2004, Eurocode 4: Design of composite steel and concrete structures – Part 1-1: General rules and rules for buildings.
- [4] Gizejowski, M.A., Salah, W.A. (2011). Numerical modeling of composite castellated beams. Prop. of International Conference on Composite Construction in Steel and Concrete
- [5] Lawson, R.M. et al. (2006). Design of composite asymmetric cellular beams and beams with large web openings. Proc. Of Journal of Constructional Steel Research 62, pp. 614-629.
- [6] Lawson, R.M., Hicks, S.J. (2011). Design of composite beams with large web openings. SCI P355, SCI, Silwood Park, Ascot, Berkshire, SL5 1QN, UK.
- [7] Sheehan, T. et al. (2015). Experimental study on long spanning composite cellular beam under flexure and shear. Journal of Constructional Steel Research, Vol. 116, pp. 40 – 54.
- [8] Wang, P. et al. (2016). Shear buckling strengths of web-posts in a castellated steel beam with hexagonal web openings. Proc. of Journal of Constructional Steel Research 121, pp.173-184.

**SJCE**

**SCIENTIFIC  
JOURNAL  
OF CIVIL  
ENGINEERING**



**SS CYRIL AND METHODIUS UNIVERSITY  
FACULTY OF CIVIL ENGINEERING**