

**SJCE**  
SCIENTIFIC  
JOURNAL  
OF CIVIL  
ENGINEERING



SS CYRIL AND METHODIUS UNIVERSITY  
FACULTY OF CIVIL ENGINEERING



ISSN- 1857-893X

Volume 11  
Issue 2  
December 2022

**SJCE**  
SCIENTIFIC  
JOURNAL  
OF CIVIL  
ENGINEERING

SS CYRIL AND METHODIUS UNIVERSITY  
FACULTY OF CIVIL ENGINEERING

### FOUNDER AND PUBLISHER

Faculty of Civil Engineering  
Partizanski odredi 24, 1000  
Skopje, N. Macedonia

### PRINT

This Journal is printed in Mar-saz  
DOOEL Skopje

### EDITORIAL OFFICE

Faculty of Civil Engineering  
Partizanski odredi 24, 1000  
Skopje, N. Macedonia  
tel. +389 2 3116 066  
fax. +389 2 3118 834  
prodekan.nauka@gf.ukim.edu.mk

### EDITOR IN CHIEF

Prof. PhD **Vladimir Vitanov**  
University "Ss. Cyril and  
Methodius"  
Faculty of Civil Engineering  
Partizanski odredi 24, 1000  
Skopje, N. Macedonia  
v.vitanov@gf.ukim.edu.mk

### ISSN: 1857-839X

### EDITORIAL ADVISORY BOARD

Prof. PhD **Valentina Zhileska  
Panchovska**  
University "Ss. Cyril and  
Methodius", Skopje, N. Macedonia

Assoc. Prof. PhD **Denis Popovski**  
University "Ss. Cyril and  
Methodius", Skopje, N. Macedonia

Assoc. Prof. PhD **Igor Peshevski**  
University "Ss. Cyril and  
Methodius", Skopje, N. Macedonia

### TECHNICAL EDITORS

MSc **Natasha Malijanska  
Andreevska**  
Assistant, University "Ss. Cyril and  
Methodius", Skopje, N. Macedonia

MSc **Ivona Nedevska**  
Assistant, University "Ss. Cyril and  
Methodius", Skopje, N. Macedonia

MSc **Frosina Panovska**  
Assistant, University "Ss. Cyril and  
Methodius", Skopje, N. Macedonia

### EDITORIAL BOARD

**Rita Bento, PhD**  
Instituto Superior Técnico,  
Universidade de Lisboa,  
Department of Civil Engineering,  
Architecture and Georesources,  
Lisbon, Portugal

**Zlatko Bogdanovski, PhD**  
University "Ss. Cyril and  
Methodius", Faculty of Civil  
Engineering, Skopje, N.  
Macedonia

**Heinz Brandl, PhD**  
Vienna University of Technology,  
Institute for Geotechnics, Vienna,  
Austria

**Maosen Cao, PhD**  
Hohai University, Department of  
Engineering Mechanics, Nanjing,  
China

**Eleni Chatzi, PhD**  
ETH Zurich, Chair of Structural  
Mechanics & Monitoring, Zurich,  
Switzerland

**Tina Dasic, PhD**  
University of Belgrade, Faculty of  
Civil Engineering, Belgrade, R.  
Serbia

**Ljupco Dimitrievski, PhD**  
University "Ss. Cyril and  
Methodius", Faculty of Civil  
Engineering, Skopje, N.  
Macedonia

**Katerina Donevska, PhD**  
University "Ss. Cyril and  
Methodius", Faculty of Civil  
Engineering, Skopje, N.  
Macedonia

**Elena Dumova-Jovanoska, PhD**  
University "Ss. Cyril and  
Methodius", Faculty of Civil  
Engineering, Skopje, N.  
Macedonia

**Michael Havbro Faber, PhD**  
Aalborg University, Department of  
Civil Engineering, Aalborg,  
Denmark

**Massimo Fragiaco, PhD**  
University of L'Aquila, Department  
of Civil, Construction-Architectural  
& Environmental Engineering,  
L'Aquila, Italy

**Tomas Hanak, PhD**  
Brno University of Technology,  
Faculty of Civil Engineering, Brno,  
Czech Republic

**Nenad Ivanisevic, PhD**  
University of Belgrade, Faculty of  
Civil Engineering, Belgrade, R.  
Serbia

**Milos Knezevic, PhD**  
University of Montenegro, Faculty  
of Civil Engineering, Podgorica,  
Montenegro

**Andrej Kryzanowski, PhD**  
University of Ljubljana, Faculty of  
Civil and Geodetic Engineering,  
Ljubljana, Slovenia

**Stjepan Lakusic, PhD**  
University of Zagreb, Faculty of  
Civil Engineering, Zagreb, Croatia

**Marijana Lazarevska, PhD**  
University "Ss. Cyril and  
Methodius", Faculty of Civil  
Engineering, Skopje, N.  
Macedonia

**Peter Mark, PhD**  
Ruhr University, Faculty of Civil  
and Environmental Engineering,  
Bochum, Germany

**Marc Morell**

Institute des Sciences de  
l'Ingénieur de Montpellier, France

**Vlastimir Radonjanin, PhD**

University of Novi Sad, Faculty of  
Technical Sciences, Novi Sad, R.  
Serbia

**Marina Rakocevic, PhD**

University of Montenegro, Faculty  
of Civil Engineering, Podgorica,  
Montenegro

**Resat Ulusay, PhD**

Hacettepe University, Faculty of  
Engineering, Ankara, Turkey

**Joost C. Walraven, PhD**

Delft University of Technology,  
Department of Civil Engineering,  
Delft, Netherlands

**Zlatko Zafirovski, PhD**

University "Ss. Cyril and  
Methodius", Faculty of Civil  
Engineering, Skopje, N.  
Macedonia

**Ales Znidaric, PhD**

ZAG – Slovenian National Building  
and Civil Engineering Institute,  
Ljubljana, Slovenia

**ORDERING INFO**

**SJCE** is published bi-annually.  
All articles published in the journal  
have been reviewed.  
Edition: 100 copies

**SUBSCRIPTIONS**

Price of a single copy:  
for Macedonia (500 den);  
for abroad (10 EUR + shipping  
cost).

**BANKING DETAILS  
(NORTH MACEDONIA)**

Narodna banka na RNM  
Account number:  
160010421978815  
Prihodno konto 723219,  
Programa 41

**BANKING DETAILS  
(INTERNATIONAL)**

Correspond bank details:  
Deutsche Bundesbank Zentrale  
Address: Wilhelm Epstein Strasse  
14 Frankfurt am Main, Germany  
SWIFT BIC: MARK DE FF  
Bank details:  
National Bank of the RNM  
Address: Kompleks banki bb 1000  
Skopje North Macedonia  
SWIFT BIC: NBRM MK 2X  
IBAN: MK 07 1007 0100 0036 254  
Name: Gradezen fakultet Skopje

S. Abazi, B. Susinov, S. Gjorgjevski IN-SITU DETERMINATION AND NUMERICAL MODELLING OF AXIAL CAPACITY OF PILES IN GRAPHITIC SCHISTS	7
Gj. Gjorgjiev, V. Gjorgjiev, N. Malijanska Andreevska BUILDING FOOTPRINT EXTRACTION FROM LIDAR POINT CLOUD DATA	13
D. Memedi, M. Partikov, D. Popovski FAILURE MODES OF I-BEAM WELDED TO SHS COLUMN JOINT DUE TO CONNECTION MODELING	23
D. Memedi, D. Popovski, M. Partikov COMPARATIVE STUDY ON HOGGING AND SAGGING MOMENT REGION OF STEEL-CONCRETE COMPOSITE FRAME BASED ON CONSTRUCTION STAGES	29
Lj. Petkovski, S. Mitovski, F. Panovska PROPAGATION OF FLOOD WAVE CAUSED BY TAILINGS DAMS FAILURE	35
Z. Srbinoski, Z. Bogdanovski, F. Kasapovski, T. Gegovski, F. Petrovski TRANSVERSE MERCATOR PROJECTION FOR THE TERRITORY OF MACEDONIA	43

**Ditar Memedi**

MSc

University 'Ss. Cyril and Methodius'  
Faculty of Civil Engineering – Skopje  
N. Macedonia

**Mile Partikov**

PhD, Assistant Professor

University 'Ss. Cyril and Methodius'  
Faculty of Civil Engineering – Skopje  
N. Macedonia  
partikov@gf.ukim.edu.mk

**Denis Popovski**

PhD, Associate Professor

University 'Ss. Cyril and Methodius'  
Faculty of Civil Engineering – Skopje  
N. Macedonia  
popovski@gf.ukim.edu.mk

## **FAILURE MODES OF I-BEAM WELDED TO SHS COLUMN JOINT DUE TO CONNECTION MODELING**

When it comes to bolted connections, the most used cross-sections for columns and beams are without a doubt the I-profile family. There is sufficient research and theoretical knowledge in the literature to determine the stiffness characteristics of moment connections of this category. The moment connection analysis methodology for this family of sections is known as the Method of Components, developed by Zoetemeijer [6], and which is also adopted in EN 1993-1-8 [2]. This method provides a theoretical evaluation of the three of the most important properties of connections, namely: Strength, stiffness and ductility, and is based on a mechanical model.

On the other hand, cases are not rare when square or circular sections, welded with I-beams, are used for columns, instead of open sections. For this configuration, according to the knowledge of the authors, there is no unified analytical formulation (adopted in the form of a code/rulebook) that would describe the three most important properties of the connections. For these reasons, in design practice, it is often the case for welded connections between square columns and I-beams that the connection is modeled as a fully rigid connection.

In this paper, an approximate method for determining the rotational stiffness for this category of welded connections is proposed, using FEM software, Ideas StatiCA 21.1.

The moment at the joint from an external load, generated by this rotational stiffness, is calculated. The effect resulting from the action of this moment including the deformation of the front face of the column is also considered.

The same deformable effects are calculated when the joint is treated as fully rigid. Finally, a comparative analysis at the level of a frame with a semi-rigid connection and a frame with an ideally rigid connection is conducted. The results and effects of these assumptions are interpreted.

**Keywords:** semi-rigid connections, rotational stiffness, column face bending, column punching shear.

## 1. INTRODUCTION

The choice of I and H sections for structural steel frame is more dominant in Europe and the USA in comparison with Japan. In these regions, modular planar frames have been applied, frames where stiffness is dominant in its plane, while around weak axis, stiffness is provided with the help of bracing system. In Japan, the situation is different, where space frames are more dominant [7]. This is achieved with the help of rectangular (RHS), square (SHS) and circular hollow sections (CHS). Depending on the dimensions, they tend to have a more equal distribution of the radius of inertia in the two main directions compared to I-sections.

Conventionally known details from this group are welded I or H beams with RHS columns, as in Figure 1.

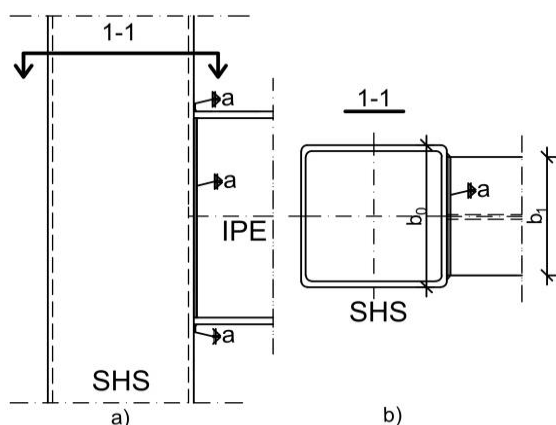

Figure 1. a) Typical welded I-beam to SHS column connection, b) base view

In design practice, a welded connection between any steel section is modeled as a fully rigid connection [11, section 2.6] Depending on the geometry of the frame, without taking into account the local stiffness and deformable characteristics of the node itself, a distribution of moments is generated.

Directly proportional to the increase in the cross-section area of the columns (RHS or SHS), the moment in the connection node also increases. If no additional stiffeners are provided in the column side, additional effects are transferred to the column walls. In the following paragraphs, the possible adverse effects in the column face (in the joint region) due to improper treatment of the beam-to-column connection are given.

## 2. ROTATIONAL STIFFNESS ESTIMATION

A initial step in order to have an idea of the transfer of the negative moment from the beam to the node of the connection, is the determination of its rotational stiffness. The deformability, i.e. the rotation of the connection  $\theta$  and the negative moment  $M_{j,Rd}$  are mutually related by the equation for the rotational stiffness according to the following expression:

$$S_{j,ini} = \frac{M_{j,Rd}}{\theta} \quad (1)$$

In the following figure 2, a numerical model between welded I-beam to SHS column connection is given, where the regions that are activated due to the transfer of moments from the beam to the beam-column connection are shown.

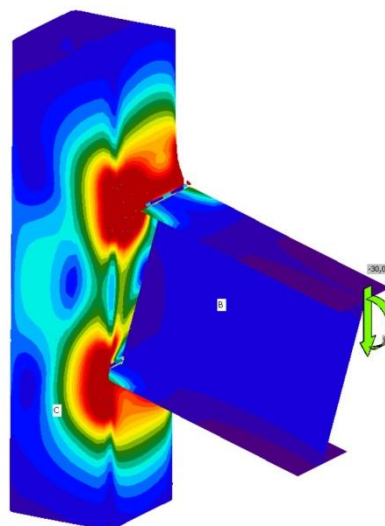

Figure 2. a) Typical physical model between welded I-beam to SHS column connection

The action of the negative moment causes deformations of certain components of the connection itself. In order to mathematically quantify these deformations (the area marked in red, Figure 2), a general approach consists in creating a Model with linear springs. Subsequently, a model is constructed that takes into account these deformed areas of the column, assuming that the beam does not yield in any load combinations.

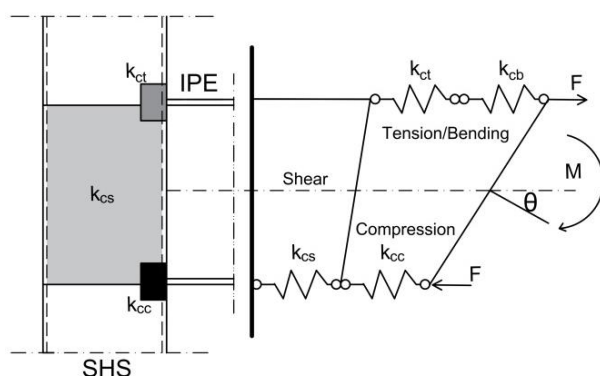

Figure 2. Mathematical model based on linear springs

The active components that make up the mathematical model are:

1.  $k_{ct}$  – Column face tension
2.  $k_{cc}$  – Column face in compression
3.  $k_{cs}$  – Column side wall shear
4.  $k_{cb}$  – Column face bending

In the paper of Godoi et al [3], expressions for the determination of the active components for the case of an I-beam welded to a circular column (SHS) are proposed. A model for determining the same active components, only in the case of a rectangular or square column welded to an I-beam, is proposed in the paper [7]. However, there is still no unified explicit solution in the form of a code for determining these active components. For these reasons, in this paper, approximate methods, based on the finite element method, have been used with the help of Idea StatiCA 21.1 software.

The approach to determining the rotational stiffness is as follows:

A welded connection between the beam and the column is modeled using CBFEM (Component-based Finite Element Method) in Idea StatiCa 21.1, [12]. All steel plates are modeled by 2D finite element method assuming ideal elastic-plastic material on the other hand, welds are modeled as nonlinear springs. The transversal load immediately next to the welded joint is calculated, and it is given as an external load in the software. The next step is to apply a bending moment as an external load.

An initial calculation of the connection is performed and the following capacities from the software are read: capacity of welds and the efficiency ratio of the all other components as well as the initial rotational stiffness at that particular step of the analysis.

If it is noted that the efficiency ratio of the all constituent elements is below 90%, it means that the obtained initial rotational stiffness is greater than the real value and the the incremental increase of bending moment  $M_{ed,i}$  ( $i$ -th step) should continue.

The analysis continues in the next step, by gradually increasing the bending moment (keeping the transverse loads constant) and reading the efficiency ratio of the constituent elements and the value of the rotational stiffness.

Such incremental analysis continues until the set moment (incremental moment) does not cause yield of any of the constituent elements to be exceeded and the rotational stiffness of the connection to drop drastically.

The moment value that does not cause yielding of the constituent components, but represents 99% efficiency ratio of the connection, generates the required rotational stiffness.

## 2.1. MODES OF FAILURE

To describe the modes of failure in connections between welded sections, it is necessary to understand the transfer of forces between the joined elements. According to the studies of Wardier [5], significant types of failures for this type of connections are:

1. Local failure of the beam flange
2. Column face wall plastification
3. Column punching shear
4. Column shear failure

In this paper, only „Column face wall plastification” and „Column punching shear” are analyzed.

### 2.1.1. SHS COLUMN FACE WALL PLASTIFICATION

The mechanism that causes this type of failure is the participation of the flanges in the plastification of the column face wall. The largest number of tests simulating the deformation of an I-beam welded to a square hollow section column were made by Makino et al. [9] and Kamba et al. [8]. In these studies, the equations for determining the bearing capacity are derived from analytical models. These equations were modified to fit the numerical data which were assumed to have a deformation of at most  $3\%b_0$ , where  $b_0$  presents column width.

In this paper, on the column wall bending, only the influence of the flanges is taken into

account. While incorporating the web as well, research and analytical equations are presented in the PhD thesis of Lu [4].

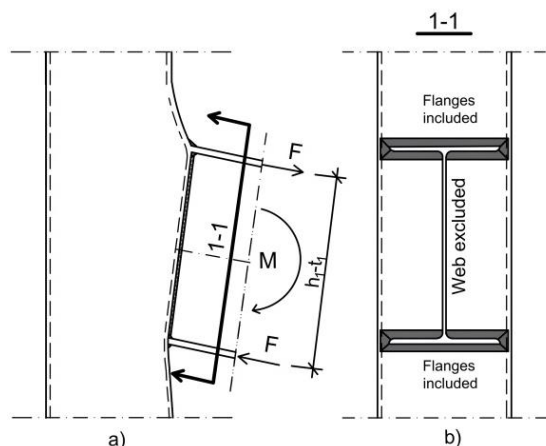

Figure 3. a) Column wall in bending b) Effect of front column face plastification (front view)

Figure 3 a) shows the deformation of the side of the rectangular column under the influence of the negative moment transferred from the I-beam. The magnitude of  $M$  is directly proportional to the rotational stiffness of the connection, which needs to be further calculated. The lever arm of internal forces,  $F$ , activates the regions in the flanges as shown in Figure 3 b) The bending capacity of the connection under the influence of the moment  $M_{Rd,CWP}$ , according to [5], is determined by the following equation:

$$M_{Rd,CWP} = \frac{f_{0,y} t_0^2 4}{\sqrt{(1-\beta)}} (h_1 - t_1) \quad (2)$$

,where:

1.  $f_{0,y}$  – yield limit for steel
2.  $t_0$  – column wall thickness
3.  $h_1$  – column height
4.  $t_1$  – beam flange width

The coefficient  $\beta$  is a quantity that depends on the ratio between the width of the side of the column in relation to the width of the flange, ie  $\beta = b_0/b_1$ . This coefficient takes values from 0.45 up to 0.85. When  $\beta > 0.85$ , the width of the column flange approaches the lateral sides of the RHS column cross-section, thus the bending capacity increases rapidly, that is, the expression (2) theoretically tends to infinity.

### 2.1.2. COLUMN PUNCHING SHEAR

The punching shear of RHS(SHS) column from the load transfer of the I-beam, according to the tests of [5] and [10], can be treated as the punching of steel plate in the RHS column. The

beam web is located on the softest side of the column face and thus is generally not effective. In the following figure, the active regions (flanges) and their effective compression and tension width  $b_e$  are shown.

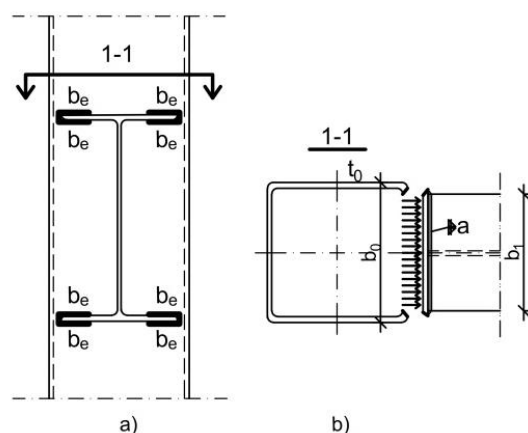

Figure 4. a) Effect of flanges on punching shear of Column b) Column punching shear (top view)

For the same grade of steel for the beam and column, the algebraic expression for determining  $b_e$  is given by [3]:

$$b_e = \frac{10}{\left(\frac{b_0}{t_0}\right)} \cdot b_1 \quad (3)$$

Where  $b_0$ ,  $t_0$  are the column side width, column wall thickness, respectively.

The force that tends to shear the wall from the column, according to the expression explained in [5] is calculated by:

$$N_{Rd,CPS} = f_0 t_0 (2b_e + 2t_1) / \sqrt{3} \quad (4)$$

$N_{Rd,CPS}$  acts on pressure and tension, and the figure 4b) illustrates the case when it acts on tension.

## 3. COMPARATIVE STUDY

### 3.1.1. DESCRIPTION OF ANALYSED STRUCTURES

In the following, 2 groups of steel frames are analyzed. In the first group, three one-bay, single-story frames are considered where the beam-to-column connection is treated with its corresponding rotational stiffness. A characteristic framework that is the subject of analysis is shown in figure 4.

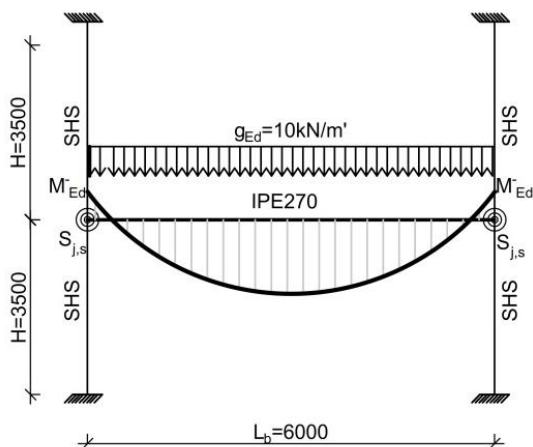

Figure 4. Characteristic one-bay, one story steel frame with semi-rigid connection

The geometric characteristics and the type of sections are given in Table 1, while the steel grade is S235. In the second group, exactly the same frames are analyzed with one difference, the connection between the beam and the column is treated as ideally rigid.

Table 1. Geometric characteristics of the steel frame

SHS column	IPE beam	L <sub>b</sub> [mm]	H [mm]
150.150.5	IPE 270	6000	3500
160.160.5	IPE 270	6000	3500
180.180.5	IPE 270	6000	3500

The beam in all connections remains with unchanged dimensions while the geometric characteristics of the column are different. The thickness of the column walls, which in all cases is  $t_0 = 5\text{mm}$ , meets the condition from the equation,

$$\frac{b_0}{t_0} = c \sqrt{\frac{235}{f_y}} + 3 \quad (5)$$

recommended by EN 1993-1-8 with the limit equal to 40. In the equation (3),  $f_y$  is the steel's yield limit Coefficient  $c$  depends on the section class, the cross section and the loadings. For SHS (or RHS), it is conservatively assumed that the width of the "flat" is equal to the external width  $b$  or depth  $h$  of the RHS minus  $3t$ . In this situation,  $180/5=36 < 40$ . The difference is in the width of the face walls, varying from 150 mm to 180 mm.

### 3.1.2. CALCULATION OF ROTATIONAL STIFFNESS AND THE CORRESPONDING HOGGING MOMENT FOR THE FIRST GROUP OF JOINTS

The rotational stiffness and secant stiffness for the three analyzed connections of this group, calculated with Idea StatiCA 21.1, are given in Table 2.

Table 2. Initial rotational stiffness and secant rotational stiffness

SHS column	IPE Beam	$S_{j,ini}$ MNm/rad	$S_{j,s}$ MNm/rad
150.150.5	IPE 270	12	9.1
160.160.5	IPE 270	5	5
180.180.5	IPE 270	2.7	2.5

The rotational stiffness decreases when the width of the column front side is increasing, while retaining the same thickness. According to the data from Table 1, the negative moments from the external load of  $p_{Ed} = 10\text{kN/m}'$  were calculated in the joint themselves, for the three connections of the corresponding frames.

Table 3. Hogging bending moments- frame with semi-rigid connections

	150.150.5 IPE 270	160.160.5 IPE 270	180.180.5 IPE 270
$M_{Ed}^i$ [kNm]	13.44	12.47	10.04

### 3.1.3. CALCULATION OF FAILURE MODES

In the following, the failure types for the three connections of the respective frames are calculated.

Table 4. Column face wall plastification ( $M_{Rd,CWP}$ ), column punching shear ( $N_{Rd,CPS}$ )

	150.150.5 IPE270	160.160.5 IPE270	180.180.5 IPE270
$M_{Rd,CWP}$ [kNm]	18.50	14.80	11.70
$N_{Rd,CPS,t}$ [kN]	18.61	17.60	15.91

It is clear from the Table 4 that for the case of a column with smaller cross-sectional dimensions, the load capacity of the column in punching shear or bending is greater compared to the column with dimensions 180.180.5.

### 3.1.4. CALCULATION NEGATIVE BENDING MOMENT FOR IDEALY RIGID JOINT

As the last step of the analysis is the determination of the negative moments in the joints of the three frames of the same external load,  $p_{Ed} = 10\text{kN/m}'$ , if the connection is considered ideally rigid.

Table 5. Hogging bending moments- frame with rigid connections

	150.150. 5 IPE 270	160.160. 5 IPE 270	180.180. 5 IPE 270
$M_{Ed}^i$ [kNm]	<b>16.65</b>	<b>18.49</b>	<b>21.10</b>

It is observed that, with the increase in the dimensions of the column from 150.150.5 to 180.180.5, the negative moment in the connection node gradually increases. In the three considered cases, the negative moment exceeds the permissible loads, according to the type of fracture, shown in Table 5.

## CONCLUSIONS

From the results shown in the Table 5, it can be seen that with the increase in the dimensions of the column (width and height), the welded beam tends to act inside from the column face wall. As the outer sides of the flanges are further away from the column outside wall, which also act as "support", the shear or bending capacity is reduced. It should be emphasized that the bearing capacity of the outside column walls, for the same connection configuration and loads, is always greater than the bending or shearing capacity of the column face wall.

According to the results shown in Table 2, it is noted that with the increase in the dimensions of the column, the rotational stiffness, and thus the negative moment in the node of the connection, decreases. These moments, shown in Table 3, are smaller than the bearing moments shown in Table 4.

On the other hand, if the connection is treated as fully rigid, the magnitudes of the negative moments (shown in Table 5) are significantly larger than Column face wall plastification ( $M_{Rd,CWP}$ ) and column punching shear ( $N_{Rd,CPS}$ ) for the corresponding connections (Table 5).

Finally, it can be concluded that, if the coefficient  $b_0/t_0$  is close to the recommended maximum value, from expression (5), and if additional stiffening of the connection itself is not foreseen, then modeling the connection as completely rigid would lead to large hogging moments than the connection capacity itself.

## REFERENCES

- [1] EN 1993-1-1: Eurocode 3: Design of steel structures – Part 1-1: General rules and rules for buildings, CEN 2005.
- [2] EN 1993-1-8: Eurocode 3: Design of steel structures – Part 1-8: Design of joints, CEN 2005.
- [3] H. Godoi, M. Miranda, Sarmanho. A, V. Alves: „Stiffness assesment of welded I- beam to RHS column connection“. Engineering Structures 267 (2022), Departament of Civil Engineering- DECIV, Federal Univesity of Ouro Preto- UFOP, MG, Brazil.
- [4] H. Lu: „The static strength of I-beam to rectangular hollow section column connections“. Phd Thesis, Delft University Press, Delft, The Netherlands, 1998.
- [5] J. Wardier: „Hollow sections in structural applications“. Delft University of Technology, The Netherlands, 2001.
- [6] P. Zoetemeijer: „Design method for the tension side of statically loaded, bolted bea-to- column connections“, Heron: 20 (1); 1974.
- [7] S. Benedetto, M. Latour, G. Rizzano: „Stiffness prediction of connections between CHS tubes and externally welded I-beams: FE analyses and analytical study“. Materials 2020, 13, 3030.
- [8] T. Kamba, M. Tabuchi: „ Database for tubular column to beam connections in moment resisting frames“, IIW doc. XV-893-95, Dep. Of Architecture, Faculty of Engineering, Kobe University, Japan, 1995.
- [9] Y. Makino, Kurbobane. Y: „ Recent research in Kumamoto University in tubular joint design“. IIW Doc XV-615-86, XV\_E\_86-108, p.28, Fac, of Engineering, Kumamoto University, Tokyo, Japan, 1986.
- [10] Y. Makino, Y.Kuraobane, K. Orita and Hiraishi: „ Ultimate capacity of gusset plate-to-tube joint under axial and in-plane loads“. Porc. Tubular Structures 4th Internaional Symposium Delft 1991.
- [11] COST C1: „Semi-Rigid Behaviour of Civil Engineering Connections“, Compoiste steel-concrete joints in braced frames for buildings .Published by the European Commission, European Cooperation in the Field of Scientific and Technical Research, Brussel, 1996.
- [12] Waldt et al.: „Component-based Finite element Design of Steel Connections“. Published by Czech Technical Univeristy in Prague, 2021.