

Physical modelling of bimrocks in large scale direct shear apparatus

Milorad Jovanovski

University Ss. Cyril and Methodius, Faculty of Civil Engineering, Skopje, R. Macedonia

Igor Peshevski

University Ss. Cyril and Methodius, Faculty of Civil Engineering, Skopje, R. Macedonia

Jovan Br. Papic

University Ss. Cyril and Methodius, Faculty of Civil Engineering, Skopje, R. Macedonia

ABSTRACT: Complex geological mixtures as bimrocks, composed of core block inclusions randomly distributed in a weaker matrix, are challenging issues for a proper characterization in a large scale relevant for rock mass range, as the overall behavior is strongly influenced by the presence of the rock fragments and by their volumetric block proportion. The article presents results from their physical modelling and tests in a large-scale direct shear box with dimensions 1,0x1,0x0,6 m, loaded with stresses in large span. The mixtures of blocks and matrix are modelled for values of volumetric block proportion of 5%, 15% and 35%. Results confirm that higher contents of volumetric block proportion lead to higher angle of internal friction and lower value of apparent cohesion, while the time of failure is longer for a higher volumetric block proportion.

Keywords: Bimrocks, volumetric block proportion, physical modeling, shear strength, time of failure.

1 INTRODUCTION

Investigation, testing and characterization of bimrocks is extremely challenging task because of the complex interactive influences of core blocks and matrix properties.

On the current level of development of the geotechnical science, few rare examples from testing of bimrocks in large scale are known. Along with this, it is very difficult to conclude how close is the prognosis of the parameters to the actual conditions which are expected in the phase of exploitation of the engineering structures.

It shall be noted that several conceptual empirical approaches are developed for predicting of overall strength of bimrocks considering the boundary conditions for unwelded and welded bimrocks. However, there is still no widely accepted empirical approach in the rock mechanics community (Sönmez et al., 2009). From the present knowledge, it is clear that the mechanical behavior for unwelded bimrocks depends on properties and relations between the core blocks, as strong rock inclusions, and the weaker matrix (Sönmez et al., 2006 and 2009). Main findings are that strength behavior of the boundary between matrix and core blocks affects the uniaxial compressive strength at rock mass level (UCSm) and it's usually increased when the volumetric block proportion (VBP) is larger.

Lindquist (1994) and Lindquist & Goodman (1994) present analyses from triaxial tests on model cores including oriented blocks having various ratios of block to matrix for unwelded bimrocks. The results lead to conclusion that the internal friction angle (ϕ) for welded bimrocks increased with increasing of VBP, whereas the cohesion (C) and UCS decrease.

Yu-Chen et al. (2019) noted that the volume fraction (V_f) within a bimrock (or bimsoil) is an essential parameter that is useful for estimating the engineering characterization of heterogeneous geomaterials.

Coli et al. (2009) showed results from large scale in situ non-conventional shear tests methodology carried out on rock mass block with dimension 80x80x50 cm. However, the testing procedure differs from the ISRM Suggested Methods for in Situ Determination of Direct Shear Strength (2007) because the failure surface is not forced to develop along a horizontal plane.

Based on both literature review related to bimrocks and to several decades of own experience gained on numerous projects, the authors conducted tests on modelled unwelded bimrocks in large-scale direct shear box with dimensions 1,0x1,0x0,6 m. This apparatus is widely used in “regular” rockfill testing for numerous cases of rockfill dams, highway embankments, reinforced soil retaining walls and in defining of interface shear strength; the interested researcher can find more information in, e.g., Jovanovski et al. (2004), Jovanovski et al. (2009) and Papic et al. (2011). In addition to this, the tests on bimrocks and selected findings will be presented below: they can serve as a basis for methodology development for future projects.

2 APPLIED APARATURE AND METHODOLOGY OF PHYSICAL MODELLING

Having bimrocks frequently in the engineering environment, a program for testing on physical model was developed at the Chair of Geotechnics at the Faculty of Civil Engineering in Skopje, R. Macedonia. All the tests were conducted at own accredited laboratory. For the goal of the tests, a direct shear-box usually used for coarse-grained rockfill material with pre-defined shearing surface and restrained side spreading of the material was used (see Figure 1).

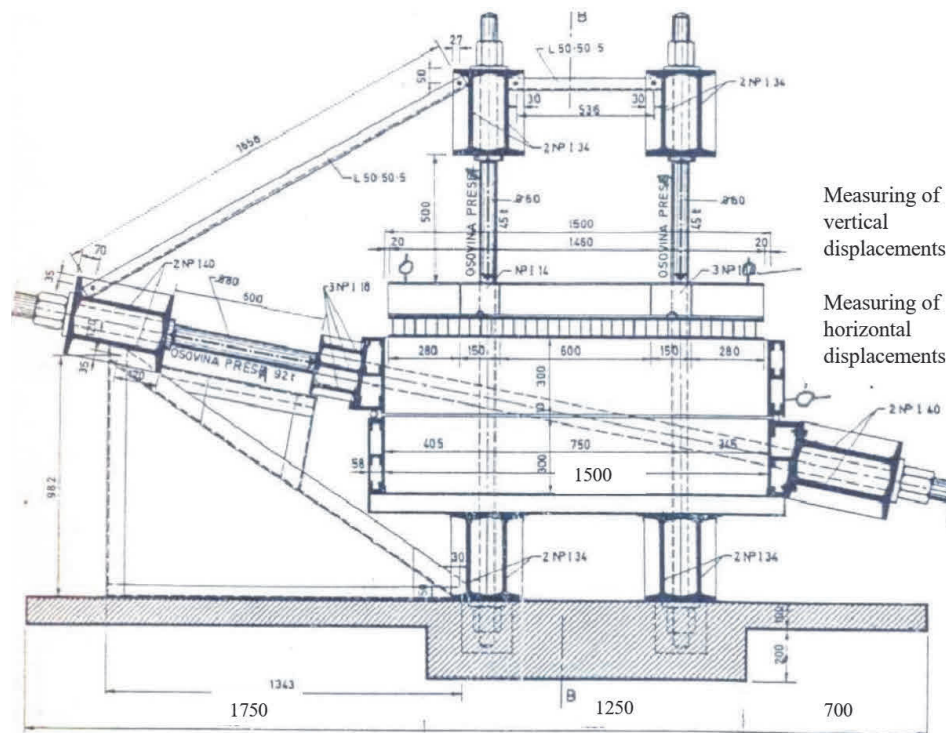

Figure 1. Large scale direct shear box with size 1,0x1,0x0,6 m applied during the testing.

The virgin version of the apparatus had size 1,5x1,5x0,6 m, but it was modified to 1,0x1,0x0,6 m in order to arrange conditions for possible appliance of relatively high normal stresses, up to 1,2 MPa. The shear box has upper and bottom frames, with heights of 0,30 m. Commonly, particles with diameter less than 150 mm are embedded. The shear surface is horizontal and it is located between the upper and the bottom frame. The normal stress is achieved with four vertical hydraulic presses (in this particular case: to apply total load of up to 1000 kN), while the shear stress is applied with two sub-horizontal hydraulic presses, mounted under an angle of 11° in relation to the horizontal plain. The bottom frame is fixed, while the upper one is movable over it, assisted by rollers which help to restrict unwanted resistance from any kind.

The tests are performed as an addition to series of “standard” direct shear tests conducted for the need of design and construction of rockfill dam “Slupcanka” in R. Macedonia. The essence of the physical model is “insertion” of core blocks in certain percentage into the weaker matrix of the rockfill, in order to examine their effect on the shear strength properties. Three such models were prepared, with volumetric block proportions (VBP) of 5%, 15% and 35% (see Figure 2).

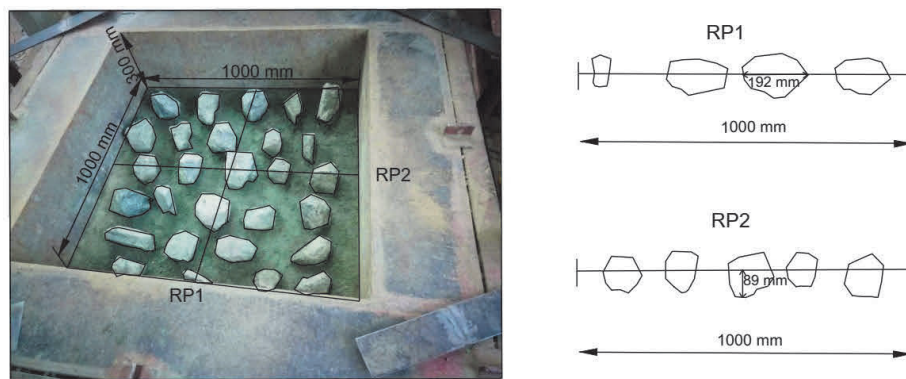

Figure 2. A view on the inserted core blocks in the weaker coarse-grained matrix with VBP≈35% placed in the bottom frame of the shear box (left) and core block position along profiles RP1 and RP2 (right).

For the modelling, material from rock quarry for dam “Slupcanka” is used. Some data about bulk density, absorption, unconfined compressive strength (UCS), tensile strength (TS) and point load strength index (Is_{50}) for intact rock parts are presented in Table 1.

Table 1. Range of values for intact rock properties of rockfill material.

Rock type	Bulk density (kN/m ³)	Absorption (%)	UCS (MPa)	TS (MPa)	Is_{50} (MPa)
Altered gabbro	27,2-27,5	0,78-1,25	66-80	4,20-6,25	0,80-2,2
Fresh gabbro	28,2-29,2	0,06-0,3	110-176	7,35-9,20	3,10-3,97

The inserted core blocks are not from same gabbro material, but for a marble with UCS=120-140 MPa. They are with dimensions from 70 to 200 mm (see Figure 2, right). The local amplitude of core pieces, related to apparatus shearing surface, are in a range 40-80 mm. The intention was to insert core blocks such as to have a position between the bottom and the upper frame of the shear box, in order to investigate their effect on shearing. Coarse-sized material as a weaker matrix, prepared dominantly from altered gabbro, is appropriately compacted thoroughly in the direct shear box, with range of values for compaction presented in Table 2. There it can be noticed that their values, for the three combinations of modelled VBP, i.e., 5%, 15% and 35%, are with negligible differences. After the installation, a vertical load is applied on the material resulting with normal stresses— per specimen – in range 200-1000 kPa over the shearing surface (see Table 2). The specified load was achieved in three stages, each of which acting until consolidation of vertical displacements (U_v) at every stage is achieved, including the maximal one (σ_{max}). After reaching the proposed vertical stress for the test, σ_{max} was maintained constant for 24 hours.

Table 2. Main parameters for compaction and volumetric block proportion used in the physical models.

Case No	Void ratio e (%)	Dry unit weight γ_d (kN/m ³)	VBP (%)	d_{50} (mm)	Applied normal stress in three levels σ (kPa)
0	0,242	22,46	/	50	250; 500; 1000
1	0,274	22,10	5	60	200; 400; 800
2	0,211	22,29	15	80	250; 500; 900
3	0,217	22,18	35	105	250; 500; 1000

A procedure of testing with known methodologies for shearing is applied on a mixture with granulometric content presented in Figure 3.

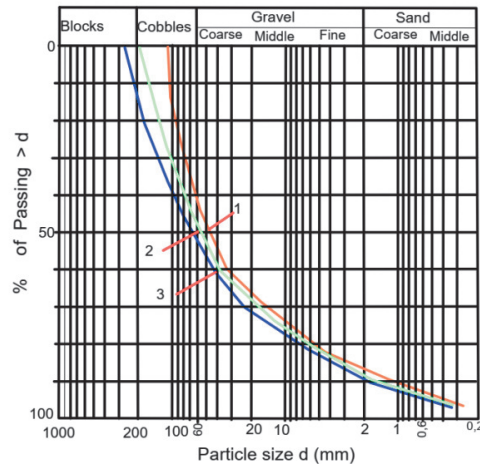

Figure 3. Granulometric curves for rockfill (1) and cases with VBP=15% (2) and VBP=35% (3).

After the consolidation, horizontal stresses (τ) are applied in stages of $\Delta\tau=1/20\sigma_{i, \max}$, each acting constantly as long as the horizontal displacements do not stop; for the stage when it is not noticed – it is concluded that failure happened along the shearing surface. For these purposes, the horizontal displacements (U_h) are permanently registered for every step of stress. In order to get a quality insight and follow the changes of the void ratio during the tests, the vertical displacements (U_v) are also registered.

3 RESULTS

The obtained results from experiments consist of total nine points for the modelled material. For their illustration, summarized diagrams for the relation of shear stress and horizontal displacement ($\tau=f(U_h)$), as well as for normal stress and shearing resistance, are presented in Figure 4. It is obvious that failures occur under displacements in a range 40-60 mm, while the positive influence of VBP is clearly presented at the right portion of Figure 4. Analyzing the obtained data, several correlations are established and presented in following equations (see also Figure 5):

$$\varphi = 0,23 \text{ VBP} + 39,33 \quad r^2 = 0,99 \quad (1)$$

$$C = 175,69e^{-0,338 \text{ VBP}} \quad r^2 = 0,99 \quad (2)$$

where, φ is angle of internal friction, C is apparent cohesion, VBP is volumetric block proportion and r^2 is coefficient of determination.

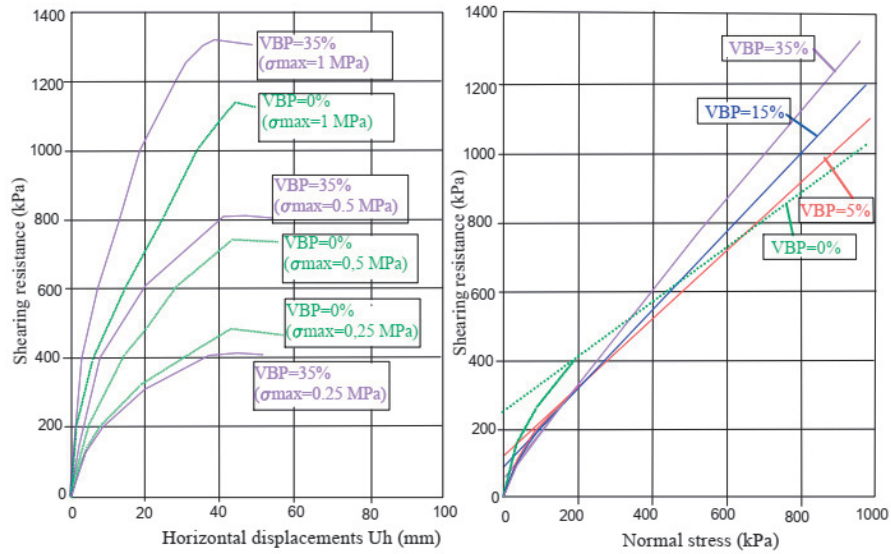

Figure 4. Summarized diagrams of the relation shear stress-horizontal displacement for a case 0 and 3 and case VBP= 35% (left) and relation shear stress-normal stress for a case 0, 1, 2 and 3 from Table 2.

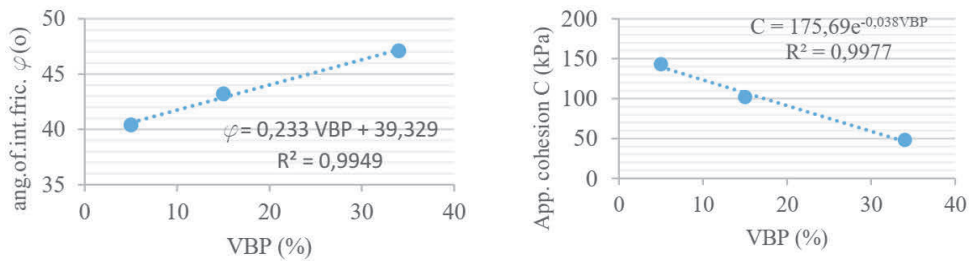

Figure 5. Correlation between the angle of internal friction (φ) and VBP (left), and the apparent cohesion (C) and VBP (right).

As it can be seen from Figure 5, very strong correlation is obtained. Therefore, it can be stated that the modelling approach gives very satisfactory results for the analyzed cases.

Also, interesting findings are related to the necessary time for failure (t). Namely, it has been noticed that increase of VBP leads to longer time to achieve failure. The illustration of this effect just for the case of maximal normal load and shearing stress to achieve failure is presented in Equation 3 and Figure 6.

$$t = 6,15 \text{ VBP} + 542,6 \quad r^2 = 0,99 \quad (3)$$

where, t is necessary time to achieve failure (min), VBP is volumetric block proportion and r^2 is coefficient of determination. These findings seem to be in agreement with those which show an increase in friction angle and a decrease in cohesion with the increase of the volumetric block proportion within the matrix (Sönmez et al., 2009). Moreover, the increasing and influence is much more expressed when VBP is larger than 25%.

Of course, for the purposes of numerical calculations related to unwelded bimrocks, it is not recommended to model them with apparent cohesion as strength parameter, while non-linearity between normal and shear stress shall be taken into consideration and respected.

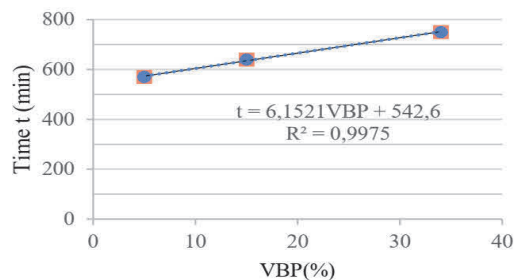

Figure 6. Correlation between t and VBP and necessary time of failure (t) for the level of $\sigma_{\max}=900$ kPa.

4 CONCLUSIONS

This presented study is a preliminary attempt to model bimrocks in large scale direct shear box with size 1,0x1,0x0,6 m and investigate the influence of different volumetric block proportions. It was found that VBP increases the angle of internal friction and extends the time for achieving failure. According to authors' knowledge, this was a first such test of artificially unwelded bimrock. The approach in this study should not be used for design purpose alone, and it can only be a support for numerical analyses and control tests during construction. The development of methodologies for similar tests on some other bimrocks with different VBP content, artificial welding of weaker matrix etc. is great challenge for future research.

REFERENCES

- Coli, N., P. Berry, D. Boldin and R. Bruno. 2009. Investigation of block geometrical properties of the Shale-Limestone Chaotic Complex bimrock of The Santa Barbara open pit mine (Italy). In Proceedings of RockEng09, 3rd Canada-US Rock Mechanics Symposium, Toronto, Canada, May 9-14, 2009.
- ISRM. 2007. Suggested Method for in situ determination of direct shear strength. In The Complete ISRM suggested methods for rock characterization testing and monitoring: 1974-2006. Suggested methods prepared by the Commission on Testing Methods, International Society for Rock Mechanics (ISRM). Compilation Arranged by the ISRM Turkish National Group, Ankara, Turkey, 2007. Editors: R. Ulusay and J.A. Hudson. 167-176
- Jovanovski M., Gapkovski N., Vitanov V., Gjorgjevski S., 2004. Methodology for testing of interface shear strength between different materials (In Macedonian), First Congress on Dams, Ohrid, Macedonia
- Jovanovski M., Gjorgjevski Sp., Papić J. Br., Josifovski J., Peševski I., 2009. Geotechnical laboratory test for determination of shearing strength of rockfill for embankment dam Rovni, R. Serbia (In Macedonian), Second Congress on Dams, Struga, Macedonia
- Lindquist, E. 1994. The Strength and Deformation Properties of Mélange. Dept of Civil Engineering, University of California, Berkley, PhD diss. UMI Diss. Svc., Ann Arbor, MI
- Lindquist, E. and R.E. Goodman. 1994. Strength deformation properties of a physical model mélange. In Proceedings of the 1st North American Rock Mechanic Symposium, Austin, Texas, 1994, eds. P.P. Nelson and S.E. Laubach, 843-850. Rotterdam: Balkema
- Papić J. Br, Jovanovski, M., Peševski I., Vitanov V., Gjorgjevski, S., Josifovski J., 2011, Alternative for Large Scale testing of interface shear strength, Workshop at Institute of Theoretical and Applied Mechanics of the Czech Academy of Sciences, Prague
- Sönmez, H., C. Gokceoglu, E. Medley, E. Tuncay and H.A. Nefeslioglu. 2006. Estimating the Uniaxial Compressive Strength of a Volcanic Bimrock. *Int. Jour. Rock Mech. Min. Sci.* 43: 554-561
- Sönmez, H., Kasapoglu K.E, Coskun A., Medley, Zimmerman R.W. 2009. A conceptual empirical approach for the overall strength of unwelded bimrocks, ISRM Regional Symp. Rock Eng. In *Difficult Ground Conditions, Soft Rock and Karst*, Dubrovnik, Croatia, pp. 29-31.
- Yu-Chen L & Yong-Ming T., Charng H.J., Jeen-Shang L. 2019. Uncertainty of volume fraction in bimrock using the scan-line method and its application in the estimation of deformability parameters, *Bulletin of Engineering Geology and the Environment*, <https://doi.org/10.1007/s10064-019-01635-7>