

See discussions, stats, and author profiles for this publication at: <https://www.researchgate.net/publication/224574015>

ULMon – Grid Monitoring from User Point of View

Conference Paper · July 2009

DOI: 10.1109/ITL.2009.5196158 · Source: IEEE Xplore

CITATIONS

2

READS

123

2 authors:



Anastas Mishev

Ss. Cyril and Methodius University in Skopje

99 PUBLICATIONS 562 CITATIONS

[SEE PROFILE](#)



E. Atanassov

Institute of Information and Communication Technologies, Bulgarian Academy of ...

98 PUBLICATIONS 458 CITATIONS

[SEE PROFILE](#)

Some of the authors of this publication are also working on these related projects:



SCISOFT-QIE (Evaluation and improvement of scientific software quality) [View project](#)



NI4OS EUROPE [View project](#)

ULMon - Grid Monitoring from User Point of View

Anastas Misev¹ and Emanouil Atanassov²

¹ *University Sts Cyril and Methodius, Faculty of Natural Sciences & Mathematics Institute of Informatics, Skopje, Macedonia*

² *Bulgarian Academy of Sciences, Institute for Parallel Processing, Sofia, Bulgaria*
anastas@ii.edu.mk, emanouil@parallel.bas.bg

Abstract. *Leveraging a complex infrastructure such as the computing Grids requires an appropriate level of monitoring. Since it is a technology in development, the current computing Grid middleware offer very little monitoring capabilities from the users' point of view. Making the Grid closer to the users requires that the users have deeper insight of what is happening with the computational jobs they submit. In this paper we present a novel tool for monitoring the gLite based Grid infrastructure from the users' perspective*

Keywords. Grid, monitoring, process mining.

1. Introduction

Many authors deeply involved in the Grid computing technology often note that it needs to be friendlier toward the users. The lack of tools for simpler use, intuitive monitoring and comfortable data management are only some of the points needed to be addressed. According to a study called SUPER [17], to make the Grid infrastructure more useful for the scientists, three areas are identified: software, policy and support. In the software area, among other requirements, there is a need for "Better tools for understanding failures and increasing reliability".

There are different approaches toward solving these problems. Some of the new tools offer complete, portal based infrastructure for job management [4], other focus on the user interface part [10]

In this paper we present a novel Grid job monitoring approach from the user perspective. It consists of several different elements working together to achieve the same goal: help the users to get better understanding and get the maximum from the underlying Grid infrastructure. It is based on the Logging and Bookkeeping data, but offers an alternative and structured view over it. It also uses some process mining algorithms to

extract the useful data and present it in a manner that will help the users improve the job efficiency rate on the Grid infrastructure.

The paper is structured as follows: in the first part we give an overview of the monitoring techniques available, in the second part we focus on the data sources that we are using in our tool, in the third part we describe the various elements and the technologies behind them, in the fourth part we describe the possibilities offered by the tool itself and we give future development possibilities and conclude in the last two parts..

2. Overview of the current monitoring capabilities of the gLite based Grid infrastructure

Most of the current monitoring tools for the computing Grids are focused on the infrastructure itself. They are mainly tools to support the site administrators and other personnel involved in maintaining the infrastructure operational. These tools are very important, since without stable and robust infrastructure, the users cannot get real benefit. But helping the users to monitor and analyze their experience with the Grid is much more important for them, since it enables them to get closer to the technology and use it to its full extend.

One of the most widely used monitoring tools for a gLite based Grid infrastructures (such as EGEE[5], SEE-GRID[15], etc) is Site Availability Monitor – SAM[9]. It offers a monitoring framework for Grid services as a framework for submission of the remote tests and collecting results of these tests in the central repository. Failures of the tests which are defined as critical cause temporary exclusion of the service/site from BDII. Site Administrator can get an alarm in case of failures of SAM tests at the services he/she is responsible for.

Another monitoring tool used is Gstat[8]. GStat is an application designed to monitor LCG compatible Grid Information Systems. GStat's primary goal is to detect faults, verify the validity and display useful data from the Information System. GStat tests the Information System approximately every 30 minutes. The test does not rely on any submitted job, but rather on queries to site GIISes/BDIIs. This is done to gather information and perform so called sanity checks to point out any potential problems with individual sites. The test covers the following areas::

- Site and service information: Provide information about the site, services, software and VOs supported at that site.
- Usage information: Provides the statistics on job slots, jobs, storage space.
- Information integrity: Checks if the Information system is publishing data that is meets specific syntax and value rules.

Real Time Monitor – RTM[14] is a tool developed by the Imperial College of London offers real time data about the job submissions to a list of sites worldwide. Besides from the global perspective, it also offers a view into site queues through the Computing Element – CE. Status for the jobs in the queue can be inspected.

Gridview[7, 13] is a monitoring and visualization tool being developed to provide a high level view of various functional aspects of the Worldwide LHC Computing Grid (LCG). Currently it shows the statistics of data transfers, FTS file transfers, jobs running and service availability information for the WLCG. It uses Relational Grid Monitoring Architecture (R-GMA) as a transport mechanism. The tool is targeted primarily for use in various Grid Operation Centers (GOCs) and Regional Operation Centers (ROCs) to monitor status of the entire Grid. It will also be used by Site Administrators and Network Administrators at various sites to view metrics for their site and by the VO Administrators to get a brief of resource availability/usage for their virtual organizations.

GridICE[3] provides status and utilization information at Virtual Organization, site and resource level, as well as basic statistics derived from historical traces and real-time alerts, and presents them through web pages. GridICE has a centralized architecture where a main server periodically queries a set of nodes to extract information about the status of grid and network services, and the utilization of resources. The main server is based on Nagios, an open source,

host and network service monitor that can be easily extended by the use of custom monitoring and notification plug-ins. For a more comprehensive list and details about the monitoring systems used for the grid infrastructure, refer to [16, 20].

As mentioned earlier, all these tools focus on the infrastructure, not on the user needs. There are several Grid portals that were intended to bridge the gap between the users and the infrastructure. Although most of them ease the process of job submission, monitoring and data management, none of them offers data analysis services crucial for the users to choose the best resources for their jobs, based on the previous user activities.

3. Data sources for the monitoring tool

The main data source used for this monitoring tool is the Logging and Bookkeeping (L&B) database. It is populated by the L&B service [19] by tracking jobs managed by the gLite WMS (workload management system). It gathers events from various WMS/RB components in a reliable way and processes them in order to give a higher level view - the status of job. Virtually all the important data are fed to L&B internally from various gLite middleware components, transparently from user's point of view.

L&B data is accessible in several ways. The mostly used is the command line tool glite-wms-job-status. It uses a job identifier (or file containing jobs identifiers) to query the service. The service returns the latest recorded status of the job, or the complete history with the entire event. The data is in textual format, useful for quick status check, but unsuitable for more advanced analysis. Another way to access the data is through its' web service interface

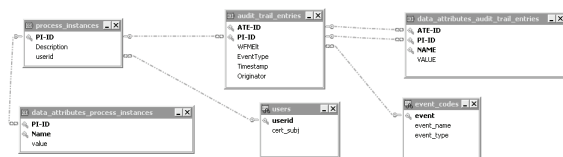

Figure 1. Database diagram

The data acquired from the L&B database is stored in a local database. The schema of the database is optimized to be used with process mining [18] tools (such as ProM [11, 18]), and it is given in the Figure 1.

4. Elements of the monitoring tool

The described tool consists of three basic elements: push service, pull service and web application, as shown in Figure 2. Also, it uses a message queuing server to share the data among the push and the pull service.

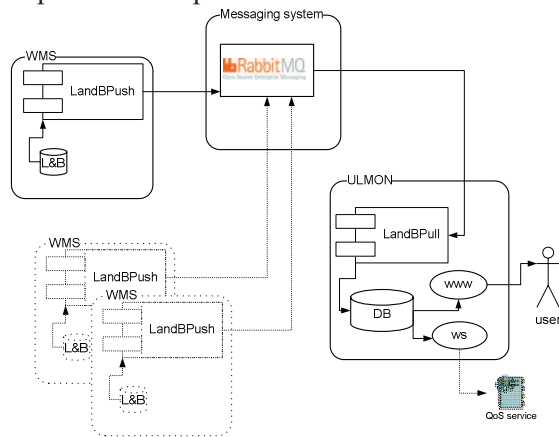

Figure 2. Elements of the monitoring tool

The first element is the push service. It is a Java application, ran as a cron job on every N minutes on the L&B element of the Grid. It can be also placed on a separate node, in which case remote access to the L&B database should be enabled. The push service connects to the L&B database and extracts data from it. The data extraction is done incrementally, using the timestamps of the jobs' events and limiting the maximum records queried per run. It transfers data from the tables: users, jobs, events and short_fields. Future versions might include long_fields table too. The data is then packed and sent to a messaging server using its Java API.

The pull service is a non-stop running service on a separate node. It is a subscriber module to the message queue. Its main loop waits for events from the message queue. As messages are received from the queue, they are transformed and written to a local database. The database uses unique indexing to avoid duplicates, which are necessary to maintain the complete data, since the push process is a periodical one and the L&B data has timestamps only on a detail level (the events table). Using this technique mitigates the pressure from the push server, i.e. the L&B database engine, making it more available for its primary purpose. It has also an associated cron script to monitor its running and restart it in case of failure.

The third element is a web based application, which represents the users' interface to the data. The application is hosted on a Tomcat container, accessible through HTTPS and using the underlying security infrastructure for certificates. Authorized users with valid X509 certificates (signed by any authority member of EUGridPMA) can access the web application. In the first version, it supports browsing through the users own jobs, showing detailed description for each of them, filtering, statistics and conversion and download of an archive with the MXML file supported by the ProM tool for offline analysis of the data. For the possibilities of the ProM analysis of the L&B data, refer to [1].

As mentioned earlier, the system uses the RabbitMQ[12] message queuing server to enable the communication between its elements. The server is an Erlang implementation of the AMQP[2], an advanced message queuing protocol. The implementation in Erlang[6] guaranties high level of availability and robustness.

The reasons for using modularity are several. First of all, it allows easy scalability by only installing the push part to several L&B elements on different sites, while keeping the same messaging and presentation servers. Another reason is the performance optimization. Using modularity, each module has a smaller CPU requirement and memory footprint. In our previous research, using single module to extract data for analysis proved to be too demanding. Here, since the data acquisition is done on a live, production L&B, the performance is more than important. The tool itself should not interfere with the primary role of the systems –logging and bookkeeping. By using the messaging queuing, there could be more pull elements also (queue subscribers), such that each site can host its own ULMon web application.

5. Features of the ULMon tool

The main difference between other monitoring tools mentioned and the one described in this paper is its orientation toward the user. It will help the users to get better insight into the jobs lifetime. It will also help them to identify preferred resources on the Grid and avoid ones that perform poorly from their point of view.

Welcome Anastas Misev

Select	user_ID	cert_subj
<input type="checkbox"/>	037b380475ee693b44065ce4422701	/DC=ORG/DC=SEE-GRID/OU=People/OU=Faculty of Natural Sciences and Mathematics-Skopje/CN=
<input type="checkbox"/>	24919a18f18180505a7a026878a0b19	/C=MK/OU=MAAR/OU=UKIM/CN=Anastas Misev
<input type="checkbox"/>	1e0b64122032450c544458e1927c134	/DC=ch/DC=cern/OU=Organic Units/OU=Users/CN=...
<input type="checkbox"/>	581a3f3a7b67a2c610ab4762799d3	/C=GR/DC=FR/OU=CNRS/OU=...
<input type="checkbox"/>	ca89a204972503496e2a002991a5e	/DC=ORG/DC=SEE-GRID/OU=People/OU=University of Banja Luka/...
<input type="checkbox"/>	01878b15499b6675a262e5c105c5628f	/C=RS/OU=ABGIS/OU=Institute of Physics Belgrade/...
<input type="checkbox"/>	ce88f0d1645e7e263266900ebb0832	/O=GRID-FR/C=FR/OU=CNRS/OU=...
<input type="checkbox"/>	51799ab481936818ab59078738e405f	/DC=bg/DC=acad/OU=people/OU=IPP-BAS/...

Show jobs | Convert to MXML

Figure 3. User selection form (as shown to the site administrator)

The tools can also be used by site administrators, in which case they can see the jobs submitted by all the users on the WMS they are administering (Figure 3). Future versions will enable more features and filtering capabilities for the administrators (filtering by CE, WN, ...).

Using its web interface the users can get more intuitive review of the events in the job's lifetime. Some of the data can be accessed through a web service, needed for the planned future usages.

Since the volume of the jobs can get very high, the users have the possibility to filter their jobs according to the submission date. Also, pagination is used to present only several jobs at the time. When the tool will be installed to multiple L&B, they can also use filtering by WMS server. For each of the listed jobs, the users can view every single logged event (starting from the job registration toward the final stages of it). For each event, additional attributes can be presented. This view is an enhancement to the command line data acquired from the job submissions, Figure 4.

Jobs for Anastas Misev submitted between 2008-11-16 and 2008-11-18

Filter jobs

Showing jobs 11 to 20

Show statistics

ID	Description	UserID	Submitted	Show events
M-RIN8mDgdyDF-UIN_Vlg	https://grid-wms.ii.edu.mk:9000/RIN8mDgdyDF-UIN_Vlg	[37b380475ee693b44065ce4422701]	2008-11-17 22:27:23.0	Show events
FGJFR7yxV2n9N7ARD04kQ	https://grid-wms.ii.edu.mk:9000/FGJFR7yxV2n9N7ARD04kQ	[37b380475ee693b44065ce4422701]	2008-11-17 22:27:29.0	Show events

Events for the job https://grid-wms.ii.edu.mk:9000/FGJFR7yxV2n9N7ARD04kQ

#	Event	Event type	Timestamp	Originator	Show details
1	REQJOB	START	2008-11-17 22:27:29.0	NetworkServer@grid-wms.ii.edu.mk	Show details
1	REQJOB	START	2008-11-17 22:27:30.0	NetworkServer@grid-wms.ii.edu.mk	Show details
2	ACCEPTED	START	2008-11-17 22:27:33.0	NetworkServer@grid-wms.ii.edu.mk	Show details
3	ENQUEUED	START	2008-11-17 22:27:34.0	NetworkServer@grid-wms.ii.edu.mk	Show details
4	ENQUEUED	START	2008-11-17 22:27:34.0	NetworkServer@grid-wms.ii.edu.mk	Show details
5	DEQUEUED	START	2008-11-17 22:27:34.0	WorkloadManager@grid-wms.ii.edu.mk	Show details
6	MATCH	START	2008-11-17 22:27:57.0	WorkloadManager@grid-wms.ii.edu.mk	Show details

Details for the event 6 - MATCH

Name	Value
DEST_ID	gjf-cs-gs-gf-fr-211501manager:lgps-gsl
REQJOB_ID	[f-00000] NS=0000000004 WWW=000002 BH=0000000000 JS=000000 LH=000000 LPMS=000000 APP=000000 LBS=000000
SRC_INSTANCE	5182

7 ENQUEUED START 2008-11-17 22:27:59.0 WorkloadManager@grid-wms.ii.edu.mk Show details

8 ENQUEUED START 2008-11-17 22:27:59.0 WorkloadManager@grid-wms.ii.edu.mk Show details

9 ENQUEUED START 2008-11-17 22:28:00.0 JobController@grid-wms.ii.edu.mk Show details

Figure 4. List of jobs, with filtering and details

The users also have the option of producing some statistics using their jobs, shown on Figure 5. The statistics include:

- Jobs summary: count of the jobs by the final status, final reason and average duration. This and the other statistics are only made on jobs matching the filtering criteria (userids, starting and/or ending submission date). It can help the users to get a summarized review of the previous job submissions. It displays also the average time in minutes that took from the first to the last event of the jobs. The users can differentiate clearly the successful from the failed jobs, along with the reasons for the failures.
- Jobs by Computing Element – CE: distribution of the jobs by the computing elements. This statistics presents an overview of the sites that the users' jobs were matched. This table is the basics for more advanced statistics following.
- Jobs with final event by CE: a pivot statistics showing distribution of the jobs and their final states by the CEs. This is the most useful statistic to the users, since out of it one could separate the sites that finish the jobs successfully from the ones that don't. The data from this table can be used by the users on future job submissions by directly specifying the CE names into the jobs requirements.
- Waiting times in the queues by CE: statistics showing the average time jobs are waiting in the queues before they start running. The table shows the time and the number of jobs by CE and by final status. Using it, the users could identify which CE start their jobs faster (on average), but also which ones result in jobs finishing, not aborting. Similar to the previous ones, this view can also help the users modify their JDL in the requirements part and include only the preferred CEs.

The tool also integrates some process mining algorithms, based on the ProM tool, to give deeper analysis of the data. There is a built in exporter to the MXML format, such that the user can get the data and do extensive ProM processing on its own computer. Other than that, some of the more interesting features of the tool have been reengineered and adopted to be used via the web interface. For the complete list of applicable ProM features to the L&B data, please refer to [17]. Initial set of available plug-ins via web are: heuristic miner to produce the heuristic network, performance sequence diagram to identify patterns in the jobs' lifetime and Petri net performance analysis to locate the bottlenecks in the workflow.

Job statistics
Jobs for Anastas Misev
submitted between 2008-11-16 and 2008-11-18

Jobs summary | Jobs by CE | Jobs with final events per CE | Waiting times in the queues with final ev

Final Event	Final reason	No. of jobs	Average time (minutes)
ABORT	that job shallow retry count (0)	8	514.6250
ABORT	Job proxy is expired	1	708.0000
CLEAR	USER	1	727.0000
DONE	Job got an error while in the CondorG queue.	1	962.0000
DONE	Job terminated successfully	9	20.6667
Total Jobs (Average time (minutes))		20	335.0000

Jobs summary | Jobs by CE | Jobs with final events per CE | Waiting times

CE	Number of jobs
ce.grid.pmf.unsa.ba.2119/jobmanager-pbs-seegrid	2
ce002.ipp.acad.bg.2119/jobmanager-lcgpbs-seegrid	2
ce01.isabella.gnet.gr.2119/jobmanager-pbs-seegrid	1
ce1.geophys.bas.bg.2119/jobmanager-pbs-seegrid	1
grf-see-grid-r5.grf.hr.2119/jobmanager-lcgpbs-grid	1
grid-ce.i.edu.mk.2119/jobmanager-pbs-seegrid	9
grid01.elfak.ni.ac.yu.2119/jobmanager-pbs-seegrid	1
grid1.urb.hr.2119/jobmanager-pbs-grid	1
n00.grid.etf.unsa.ba.2119/jobmanager-pbs-seegrid	1
sn0.hpcc.szaki.hu.2119/jobmanager-lcgpbs-seegrid	1
testbed001.grid.ici.ro.2119/jobmanager-pbs-seegrid	1
Total Jobs	21

Jobs summary | Jobs by CE | Jobs with final events per CE | Waiting times in the que

CE	DONE	CLEAR	ABORT
ce.grid.pmf.unsa.ba.2119/jobmanager-pbs-seegrid	1	0	1
ce002.ipp.acad.bg.2119/jobmanager-lcgpbs-seegrid	0	0	2
ce01.isabella.gnet.gr.2119/jobmanager-pbs-seegrid	0	0	1
ce1.geophys.bas.bg.2119/jobmanager-pbs-seegrid	0	0	1
grf-see-grid-r5.grf.hr.2119/jobmanager-lcgpbs-grid	0	0	1
grid-ce.i.edu.mk.2119/jobmanager-pbs-seegrid	9	0	0
grid01.elfak.ni.ac.yu.2119/jobmanager-pbs-seegrid	0	0	1
grid1.urb.hr.2119/jobmanager-pbs-grid	0	0	1
n00.grid.etf.unsa.ba.2119/jobmanager-pbs-seegrid	0	0	1
sn0.hpcc.szaki.hu.2119/jobmanager-lcgpbs-seegrid	0	0	1
testbed001.grid.ici.ro.2119/jobmanager-pbs-seegrid	0	1	0
Total Jobs	10	1	10

Jobs summary | Jobs by CE | Jobs with final events per CE | Waiting times in the queues with final events per CE

CE	Final event	No. of jobs	Average waiting time in the q from ACCEPT to RUNNIN
ce01.grid.etf.unsa.ba.2119/jobmanager-pbs-seegrid	ABORT	1	2.0000
ce.grid.pmf.unsa.ba.2119/jobmanager-pbs-seegrid	ABORT	1	2.0000
ce.grid.pmf.unsa.ba.2119/jobmanager-pbs-seegrid	DONE	1	2.0000
ce01.isabella.gnet.gr.2119/jobmanager-pbs-seegrid	ABORT	1	2.0000
ce01.moosgrid.uchj.ro.2119/jobmanager-pbs-seegrid	ABORT	1	4.0000
cluster1.csk.kg.ac.yu.2119/jobmanager-pbs-seegrid	DONE	1	2.0000
coo01.grid.metu.edu.tr.2119/jobmanager-lcgpbs-seegrid	ABORT	1	2.0000
grf-see-grid-r5.grf.hr.2119/jobmanager-lcgpbs-grid	ABORT	1	4.0000
grid-ce.i.edu.mk.2119/jobmanager-pbs-seegrid	DONE	9	19.2222
grid01.elfak.ni.ac.yu.2119/jobmanager-pbs-seegrid	ABORT	1	2.0000

Figure 5. Users statistics

6. Future development and integration

The next step into the development of the tool is verifying its' scalability. It will be installed on a production environment, using several different L&B elements to gather more data. We don't expect many scalability issues, since the tool is modular and we expect to scale well.

This tool, apart from being used as a standalone tool, will be enhanced to play a role in enforcing some form of Quality of Service (QoS) on the Grid infrastructure. The data gathered by the tool will be made accessible in machine format (using web services). It will be used in conjunction with another tool to monitor the conformance of the infrastructure to the QoS requirements of the users.

The AMQP protocol opens various possibilities for interoperation not only with Grid services and Grid operational tools, but also

with non-Grid services like e-mail/instant messaging/etc.

7. Conclusions

With the introduction of the described tool, we hope to enable the users to get deeper understanding of their jobs' lifetime and workflow. Also, using the tool they could have their own perspective on the underlying infrastructure and select only the sites that performed best for them in the past. The job view gives the users much more information about their job submissions than the usual command line tools. Each of the presented statistics goes beyond the usual way of presenting the data to the users. Using it, they feel much more comfortable to use the infrastructure.

Integration of the data acquired by the tool into some other services is another important benefit. Novel services like user based Quality of Service can rely on the same set of data to guarantee or verify the enforcement of the required level of service.

One other important novelty is the application of message queuing technology over the Grid infrastructure. Message queuing protocols like AMQP will play an increasing role in the evolution of Grid infrastructures.

8. Acknowledgments

This paper is based on the work done in the framework of the SEE-GRID-SCI FP7 EC funded project, with partial support from NSFB grant D002 - 146/2008.

9. References

- [1] A. Misev and E. Atanassov: Performance Analysis of GRID Middleware Using Process Mining, 8th International Conference, Kraków, Poland, June 23-25, 2008, Proceedings, Part I Series: Lecture Notes in Computer Science, Vol. 5101, pp.203-214. (2008)
- [2] Advanced Message Queuing Protocol - AMQP. <http://www.amqp.org/>, visited December 2008. (2008)
- [3] Alexandre Duarte, D. Carvalho, Pedro Henrique Rausch Bello, Operating a Transatlantic Grid Infrastructure, Proceedings of the Third Conference of the EELA Project CIEMAT 2007 (2007)

- [4] Csaba Németh, Gábor Dózsa, Róbert Lovas and Péter Kacsuk, The P-GRADE Grid Portal, Computational Science and Its Applications – ICCSA 2004, Lecture Notes in Computer Science, Volume 3044/2004, pp 10-19. (2004).
- [5] EGEE - Enabling Grids for E-science, <http://www.eu-egee.org/>, visited December 2008
- [6] Erlang. <http://www.erlang.org/>, visited December 2008 (2008)
- [7] GridView-Monitoring and visualization tool for LCG, <http://gridview.cern.ch/GRIDVIEW/>, visited December 2008. (2008)
- [8] GStat http://goc.grid.sinica.edu.tw/gstat/filter_help.html visited December 2008
- [9] J. Andreeva: MONITORING OF THE COMPUTING ACTIVITIES OF THE LHC EXPERIMENTS FOR THE CCRC08 AND BEYOND, The 3-rd International Conference "Distributed Computing and Grid-technologies in Science and Education" June 30 - July 4, 2008, Dubna, Russia
- [10] Paweł Wolniewicz, Norbert Meyer, Maciej Stroiński, Mathias Stuempert, Harald Kornmayer, Martin Polak, Harald Gjermundrød: Accessing Grid Computing Resources with g-Eclipse Platform, COMPUTATIONAL METHODS IN SCIENCE AND TECHNOLOGY 13(2), pp. 131-141 (2007)
- [11] ProM tool for Process mining, <http://www.processmining.org/>, visited December 2008 (2008)
- [12] RabbitMQ. <http://www.rabbitmq.com/>, visited December 2008. (2008)
- [13] Rajesh Kalmady, Digamber Sonvane, Kislav Bhatt, Phool Chand, James Casey, Zdenek Sekera: GRIDVIEW : A GRID MONITORING AND VISUALIZATION TOOL, Computing in High Energy and Nuclear Physics – CHEP06, Mumbai, India, 13-17 February 2006. (2006)
- [14] Real Time Monitor: <http://gridportal.hep.ph.ic.ac.uk/rtm/>, visited December 2008
- [15] SEE-GRID – South Eastern Europe GRID-enabled eInfrastructure Development, <http://www.see-grid-sci.eu/>, visited December 2008
- [16] Serafeim Zaniolas Rizos Sakellariou: A taxonomy of grid monitoring systems, Future Generation Computer Systems Volume 21, Issue 1, 1 January 2005, Pages 163-188 (2005)
- [17] Steven Newhouse, Jennifer M. Schopf, Andrew Richards, and Malcolm Atkinson: *Study of User Priorities for e-Infrastructure for e Research (SUPER)*, Proceedings of the UK All Hands Meeting, Sept 2007 (2007).
- [18] van der Aalst, W.M.P. and Weijters, A.J.M.M. editors: Process Mining, volume 53 of Special Issue of Computers in Industry. Elsevier Science Publishers, Amsterdam, (2004)
- [19] Z., Sitera, J., Skrabal, J. and Vocu, M.: Advances in the L&B Grid Job Monitoring Service, http://lindir.ics.muni.cz/dg_public/lb2.pdf, visited December 2008 (2008)
- [20] Zoltán Balaton, Peter Kacsuk, Norbert Podhorszki and Ferenc Vajda: Comparison of Representative Grid Monitoring Tools, Report of the Laboratory of Parallel and Distributed Systems, Hungarian Academy of Sciences, (2000)