

# INTEGRATION OF A COURSE ENROLMENT AND CLASS TIMETABLE SCHEDULING IN A STUDENT INFORMATION SYSTEM

International Journal of Database Management Systems ( IJDMS ), Vangel Ajanovski

## Cite this paper

Downloaded from [Academia.edu](#) 

[Get the citation in MLA, APA, or Chicago styles](#)

## Related papers

[Download a PDF Pack](#) of the best related papers 



[Automating Class Schedule Generation in the Context of a University Timetabling Information...](#)

Tauseeq Tufail

[Tabu Search Based Hyper-Heuristic Approaches to Examination Timetabling](#)

Naimah Mohd Hussin

[PREFERENCE DRIVEN UNIVERSITY COURSE SCHEDULING SYSTEM](#)

Badri Prakash Ojha

# INTEGRATION OF A COURSE ENROLMENT AND CLASS TIMETABLE SCHEDULING IN A STUDENT INFORMATION SYSTEM

Vangel V. Ajanovski<sup>1</sup>

<sup>1</sup>Faculty of Computer Science,  
Saints Cyril and Methodius University, Skopje, Macedonia  
vangel.ajanovski@finki.ukim.mk

## **ABSTRACT**

*This paper is dealing with the most important issues of two of the most significant university administrative processes – the process of term enrolment with course enrolment and the process of organization of classes and scheduling a conflict-free class timetable. In the first part of the paper an introduction to the problem is set and the impact and interrelation of the two processes is explained in detail. In the second part of the paper, the focus is on the process of class timetable scheduling, with an analysis of how severe is the risk of having conflicts in the class schedule. Conflicts in the class schedule are rarely introduced due to the lack of resources, in the usual understanding of the term, but are mostly related to the availability human resources. The analysis gives more details on the probability that the students will have a conflict in the timetables among different courses they attend. The third part of the paper discusses some of the formal complexities of the course enrolment process and gives short overview of an earlier effort to overcome such complexities with an introduction of a virtual academic adviser. The virtual adviser components, are then integrated with a recommender system that gives each student personalized course recommendations based on historical data of courses and success. Finally, a solution is given in the form of a model that is currently under development in which a single unifying process is envisioned that covers both earlier processes. The integrated process defines a continuous dialogue between the student groups, enrolment administration and scheduling administration. It is expected from the solution to streamline both processes into a fully integrated system that will improve the student satisfaction from the organization and transparency of the administration.*

## **KEYWORDS**

*Administrative processes, Course Enrolments, Recommender Systems, Scheduling.*

## **1. INTRODUCTION**

One of the major administrative processes at the universities in the country is the course enrolment. During this process, which starts 3 weeks before the beginning of classes, the students have to enrol for the next term submitting an on-line application listing all the courses that they wish to study. This application is later reviewed by academic advisers and if approved, the students submit official documents for the term enrolment and are enrolled for all the approved courses. The students are then automatically listed and given permissions in all the learning management systems used by each course.

The other significant process is the scheduling of class timetables which is usually started before the course enrolment and goes on in parallel, sometimes even until the middle of the term. This process start with the assignment of professors to courses, resulting in a first version of the class timetables, and later when students start to join – handle the assignment of teaching assistants and

demonstrators for computer labs. Demonstrators are elected from the enlisted on an internal open call to all phd students and researchers. The number of assigned teaching assistants and demonstrators per course, largely depends on the number of enrolled students, which makes this process unable to finish until a solution for all groups of students for all courses is found. Due to these interdependencies, this process is usually late by significant amounts. In fact, in the last term at the institution of the author, although there was a regular start for all the lectures, the process of creating timetables and assigning assistant and demonstrators delayed the start of the lab-work on many courses for as much as 4 weeks.

Another source of problems are constant changes in the legislation, pushing for immediate restructuring in the organization of administration work and changing of the process rules. According to the latest legislation each study program has to have at most 50% of mandatory courses, at least 40% of elective courses – within the academic discipline, and at least 10% left as a completely free choice. Besides the choice within the study program, the students can choose from a number of study programs leading to various specializations, even within a single university department. For example, the Faculty of Computer Science and Engineering gives the possibility of choice among 8 different study programs and some of these programs offer up to 10 various specialization profiles.

The class scheduling of courses for students in the 1<sup>st</sup> and 2<sup>nd</sup> year is usually simple, only limited to room and equipment constraints. But when taking into account students enrolled in courses from the 3<sup>rd</sup> or 4<sup>th</sup> year, where only a few of the courses are mandatory and all others are elective, it is increasingly hard to find good solution for the timetables, and it is no more possible to create a static timetable valid for every year, with minor changes. In fact the groups have increasing diversity, and in every semester it is a different situation. For courses that have been going on for years the total number of students per course can be forecast within some degree of accuracy, but there are many courses that are new, or changed or restructured within the study program. Even if it was possible to forecast the total number of students for all courses, it would be still impossible to know, for each course, in advance if it would conflict other courses if the same students are enrolled to both.

All of this makes a significant impact on the success of the processes of creating course timetables and course enrolments and the overall satisfaction of the students with the organization. There are usually many conflicts in the class schedule, preventing students to attend lectures or lab course-work. There are many situations where these conflicts, or the fact that the student was not able to get a quality advice and enrolled in an incompatible course, which provokes changes in course enrolments. Students drop out from incompatible courses, the student numbers assigned do the teachers are not correct, later students enrol to other courses and this process can sometimes take even more than 10 weeks, so such students loose all possibilities to have a regular class attendance in the newly selected courses.

## **2. THE PROBLEM OF TIMETABLE INTERDEPENDENCIES**

We define course timetable interdependencies for a single course, as the number of distinct other courses that at least some of the students on this course have enrolled to attend in parallel. We denote this number with *CTI*. We are especially worried where this number affects many students, so we also analyse the number of affected students affected by a pair of courses (*CNPA*) and the rate between these two numbers (*CTIR*). An earlier preliminary analysis in the data records resulted with the fact that the *CTI* in the last 2 years has had an average of around 20 courses, with a minimum of 2 courses and maximum of 45 courses.

This clearly told everyone that there is always some interdependence between course timetables which can not be overcome until all the enrolments are known. Table 1 shows an excerpt of the

results of further analysis showing the top 10 courses with largest CTI and the cumulative number of pairs (student,course) that are affected (denoted as CNPA).

Table 1. Top 10 courses according to the CTI number

Course Code	CTI	CNPA	CTIR
IT	45	539	12
SS	42	432	10
VD	41	474	12
BP	40	295	7
SI	40	511	13
PKM	39	369	9
BM	36	241	7
BMT	36	250	7
USP	35	337	10
KG	32	250	8

Sometimes the number of affected student per pair of courses is low, and sometimes is big, but it definitely varies significantly. Table 2 shows an example of the CTI for a single chosen mandatory course in the last term in the 2<sup>nd</sup> year. This course is also presented in Table 1 and is among the top 10 courses. As can be seen from the analysis, although the CTIR is small (7), since it varies significantly (from 1 to 47), it cannot be taken as a certain indicator whether this course should be given priority for scheduling.

Table 2. An excerpt of the interdependencies of a course, with number of affected students

Course	Other course	No. of affected students
BP	SI	47
BP	SS	29
BP	VD	22
BP	IT	21
BP	BMT	19
BP	PKM	16
BP	MOS	15
BP	NM	13
...	...	...
...	...	...
...	...	...
BP	KG	1
BP	MMI	1
BP	DISK2	1

The analysis on the historical data in the last 8 years shows that the average CTI per term for all terms is 15.43, and the average CCNA per term for all terms is 202.

Usually, the staff responsible for the scheduling used an intuitive idea that two certain courses are only taken at the same time if they are in the same semester of related study programs from the same department and that there are usually only 5-6 such courses per semester. The analysis shows that a timetable without conflicts has to be planned, for an average of 15 courses with possible conflicts (instead of 6) and with an average group of 13 affected students per such course. As mentioned above and presented in Table 1 and 2, these number can vary significantly

rising to a group of 45 courses with possible conflicts with a single course and the number of affected students can be much bigger.

Unfortunately, for the case of the institution of the author, it is hard to analyse in more depth the conflicting timetables in the past, because the timetables were never collected and the data about the distribution of students per group within a single course and the attendance per class were never systematically recorded. Therefore, a full analysis on the impact of the conflicting timetables especially regarding number of missed attendances and drop-outs cannot be done.

As many other computer science departments we have tried several approaches and different timetable generation solutions to solve the problems. Many were manual, and some experiments were done using automatic generation of class timetables. The problem with automatic generation is that the system needs many constraints as input in order to really work, and so the results of the many tests were not satisfactory from the point of cohesiveness of the classes. Intuitive approach of staff that have experience with scheduling gives much more appropriate results generally with minor complaints about conflicts. On the other hand, this whole discussion served in the direction that a manual solutions that will take care of so many diverse conflicts is nearly impossible. The results are that there are certainly many conflicts that students have and they choose to prioritize which classes they will attend and or not, depending on possible repercussions of lack of attendance at those courses. This generally results with lower quality of students' work, and even a number of drop-outs. Therefore, a systemic solution has to be found if the overall quality of the education process is to be maintained.

### 3. THE PROBLEM OF CHOICE IN COURSE ENROLMENT

Significant part of the problem of choice in the course enrolment process is the problem of prerequisite dependencies between courses. One type of such dependencies mandates that a student must already have acquired a passing grade on one course to be able to take the following course. The other types of dependencies loosen this prerequisite a bit, and allow the student a certain grace period of up to one term to acquire the missing grade. In that period he is obliged to finish the missed prerequisites. While he is able to follow classes on the new courses, will not be able to take new exams and will not be allowed to get a final grade until all prerequisites are fulfilled.

There are 6 types of such dependencies and prerequisites, further complicating the problem, such as parallel attendance, or number of credits, or certain certificate, etc. Figure 1 presents a graph of dependencies regarding prerequisites between courses. It is an oriented graphs and on this picture there are two colour markers for each branch.

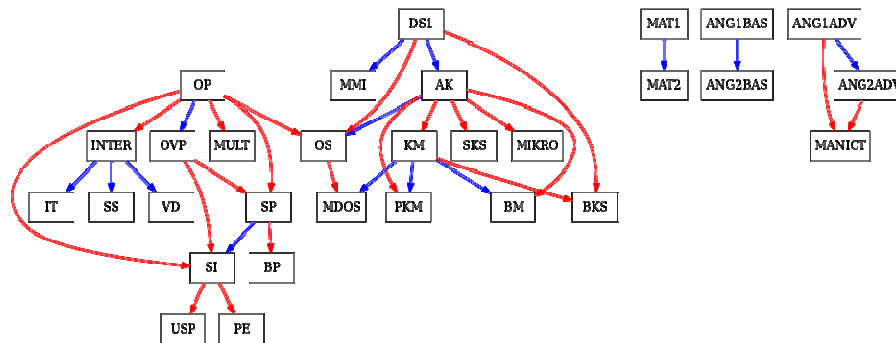

Figure 1. Example tree of course prerequisites for a 3-year study program

The student has to be aware of such interdependencies in order to enrol the right courses at the right time. Otherwise, if the student gives priority to courses that are fully elective and that do not lead to a certain degree, he takes a risk of delaying his graduation. If the chain of dependencies for some final-year course has a length of 4, it means that the student has to pass 4 prerequisite courses in the right order in 4 different terms (so it will take 2 years just to pass the prerequisites). So if the student found out to have never enrolled such an important course and it is already his 3rd year, it might be too late and he might have to study an additional year.

On many occasions, elective courses the students take can be too hard for them personally (due to various reasons), and it is realized rather late after the start of the term. In such case, drop out might not be possible, and the student might take significantly longer time to pass the course, or take more time risking the success even on other courses, or otherwise fail the course. Again, depending on the situation and how successful the student is in general, such failure can delay the graduation, because if every semester the student takes 30 credits, and fails some electives, although he will have the mandatory courses as prerequisite for the graduation, he will not have at least 240 total credits as required for graduation and will have to enrol at least one more term to attend additional elective courses.

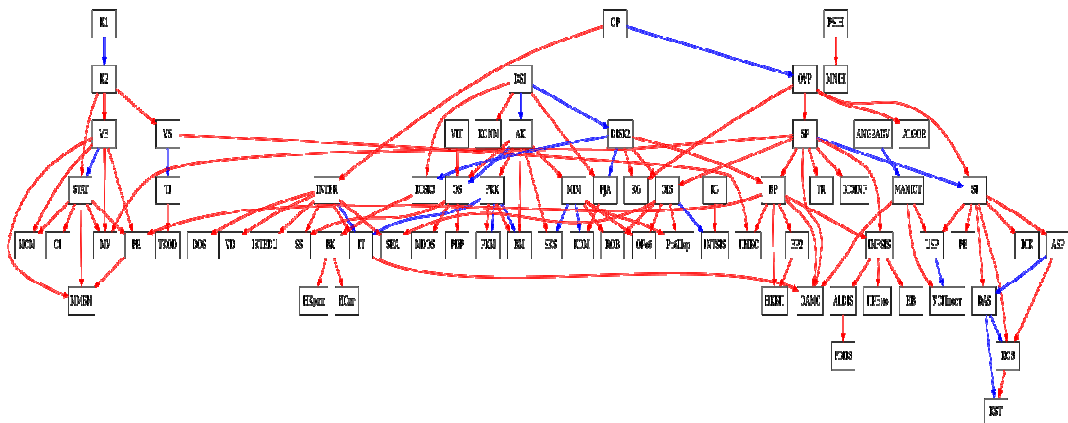

Figure 2. Example tree of course prerequisites for a 4-year study program

Advisers are trying to increase the awareness of students for such complex issues, but on many occasions they are either not consulted or did not even have a chance (due to time constraints) to discuss such details. In many situations the advisers are not competent enough themselves and the students are redirected to professors in order to confirm their choice. Having in consideration that the adviser has to know the situation for many study programs (on Figure 1 and 2 are presented the prerequisites for two study programs), such incompetence is understandable. It becomes obvious that having a sufficient number of academic advisers that have sufficient skills is a complex problem and unless alleviated by automatic means it would become impossible to maintain the quality of the education process.

In an earlier effort (see [1]), we described this problem in more detail and presented a solution for a full information system for students and created by students (called Integrated Student Information System – ISIS). The system was fully developed and started operation in 2009, part of the system was a relatively successful but simple course enrolment process that merely checked for dependencies, restricted the students to make valid choices and generally eased the process from the point of the academic adviser.

Later we proposed the introduction of a new component - virtual academic adviser (see [2]), that shows visually the length of the study program and the impact of interdependencies and prerequisites between courses and enables the student to forecast the period until graduation. Figure 3 shows a screen-shot of the virtual academic adviser component (web page). As can be seen it looks like a dashboard, showing a map of all the previously enrolled terms and the courses selections in each term – visually distinguishing the successful courses from unsuccessful ones.

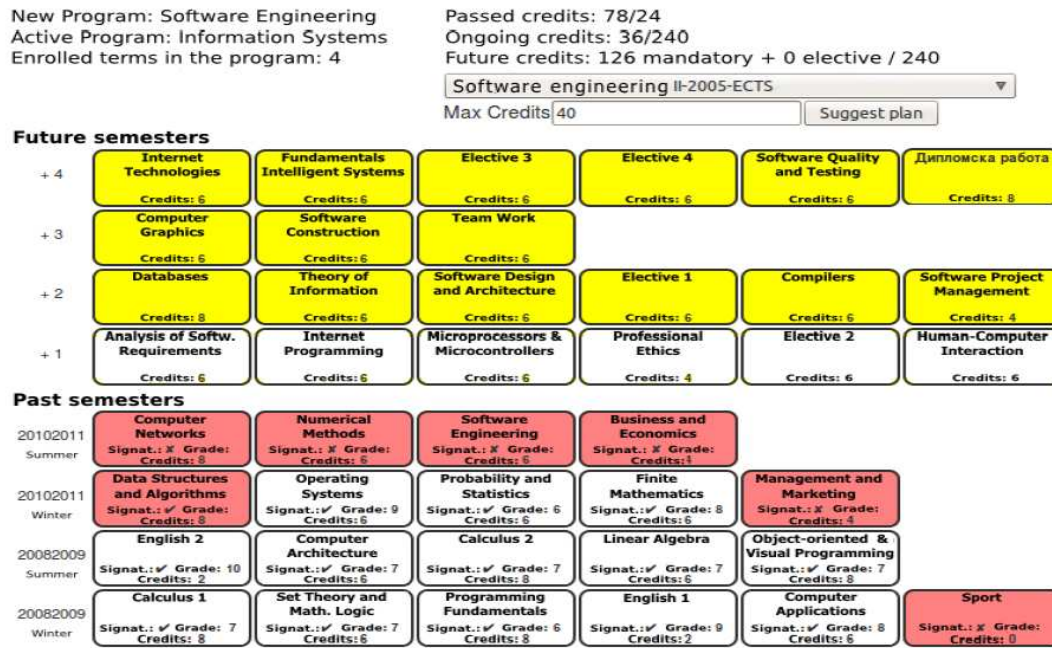

Figure 3. The Virtual Academic Adviser web page.

This dashboard gives the student several measures of his success in comparison to other students. The student can see his speed in acquiring and passing credits and compare it with the average of his generation and with the historical average of previous generations at the same year of studies. The academic terms the student will have to enrol in the future are mapped according to the average speed of other students up to the forecast graduation of the students, as shown on Figure 3. The lower part are the past terms and the upper part with yellow boxes shows an estimate of the future terms, the order is chronological from bottom to top.

The system takes into account interdependencies and course prerequisites and will propose a realistic plan. Of course whether this plan will succeed depends only on the ability of the student to follow and stay through exactly to the new plan. The system also visually indicates courses that are critical in the future term, meaning there was a significant amount of failed students. Parameters as such, are configurable by the student and are shown on the top of the page and after changing, the page is recomputed with the forecast number of terms until graduation and all the remaining mandatory courses are repositioned in the relevant future terms.

#### 4. RECOMMENDER SYSTEM FOR COURSE ENROLMENT

As in the example of many other institutions, there is an ongoing effort to include adaptive social-based components to help the process of course enrolment (see [3],[4],[5]). While the virtual academic adviser component in the initial version helps to alleviate formal problem with the

course selection each student makes and it's impact, the plan is to integrate a recommender system that will use earlier data to predict courses that would somehow relate to each student.

In the new version of the ISIS the virtual academic adviser is used as the main web page to perform term and course enrolment. If there is an active term for enrolment it is labelled in white colour and slots in this term are click-able. The system generates an initial list of mandatory courses that the student should attend according to the study program schedule. The left space to the right is filled with empty course enrolment slots, marked with a “star”. Clicking on an empty slot, creates a new course enrolment and the student is allowed to choose from a list of courses.

Figure 4 is a screen-shot of the prototype of the new dashboard. The generation of the list of courses is delegated to a separate service in the system which combines the following four categories and performs prioritization in the course list based on evaluated recommendations:

- ◆ Elective courses necessary to acquire a certain specialization;
- ◆ Elective courses specified from the study program;
- ◆ Elective courses from the department;
- ◆ Elective courses from the whole university.

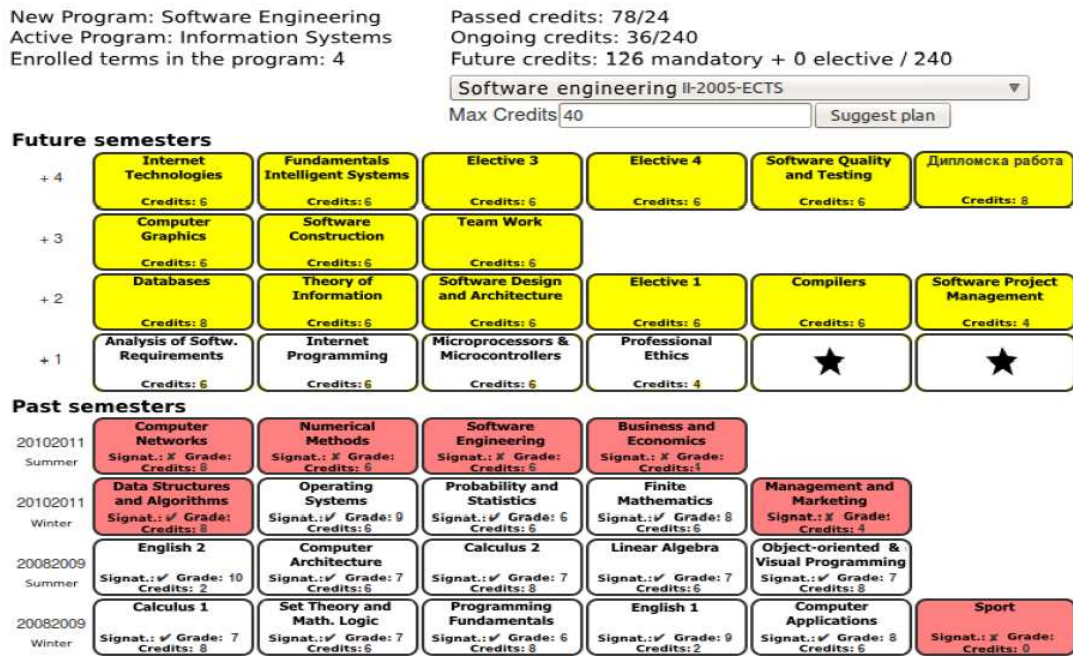

Figure 4. The Virtual Academic Adviser in a course enrolment scenario

As a recommender system, the open-source software Easyrec was chosen (see [6]), because it is a separate system with possibilities for extending via plug-ins and possibility to use the same system as a solution even for other web applications with similar requirements and the integration is done via REST and SOAP. Only a very simple modification was needed, a predefined code invocation, to enable the feeding of new course enrolment actions in the database of the recommender system. The historical data regarding actions of the enrolment were directly imported in the action database of the recommender.



## 5. INTEGRATED SOLUTION SCENARIO

The idea for a new scenario lies on the premise of rapid on-demand allocation of resources. Such a system, expects that students, teachers and administrative staff collaborate pro-actively and daily to streamline the process. Most of the effort is on the students and administrative staff, while only the least amount of requests are turned over to teachers. On a overview level description the scenario has the following steps in this exact order:

1. Professors indicate the courses that they would be able to teach. Especially new elective courses that previously were not listed. Since these lists rarely change, this will not require much effort and can be done by copying plans from the previous term.
2. Administrators for class timetables generate a first plan including just lecture hours and minimum possible number of hours for exercises and lab work, as a copy from an older plan. The maximum capacity of each room is indicated.
3. Students are able to enrol to courses as previous. The difference is at the point when they have to choose a course, that they are also given a view of their personal class timetable with all the optional time slots for all enrolled courses. In order for the application for term enrolment as a whole to be successful they must have indicated the time slots for all enrolled courses. If there are no free places in any of the time slots, they will still not be able to submit the application for enrolment, but their possible course enrolment is recorded as on a waiting list.
4. The administrators for class timetables monitor the situation closely and add more time slots for student groups when there is sufficient demand from students on the waiting list. The slot they create for the students in the waiting list, will have to be in such a time period, that will be free for all the students on the list. So, no conflict will occur.
5. At any point a student is able to mark his term enrolment as problematic and write-down a notification to the administrative staff as to the reasons that a special treatment is needed. Sometimes this can be falsely unfulfilled prerequisites, missing data in the system, request to be exempt from attendance on a course, etc. This remark can be entered as general or per course, so it can be processed separately.
6. The administrator for enrolments monitors the situation and approves different special requests. Requests for exemption of attendance or prerequisites are marked to be reviewed by the professors of the courses.
7. Professors are given notification for problematic course enrolments, they have the choice to approve / reject / ask for more information.
8. The administrator for enrolments monitors the number of processed requests and issues automated general notifications to all relevant parties when deadlines are near in order not to delay the process.
9. The system automatically approves all term enrolment applications that are submitted as complete and the student are informed via email that they have to proceed with the relevant paperwork (payment of tuition fees, taxes, etc.)
10. The relevant supervisor oversees the whole process, over a report of problematic applications, order by age. If a problem is not solved in due time, the supervisor can manually override and give approval to the student request and that action is also recorded.

11. Professors in the end get a live report of all the enrolled students, time slots, and of all special cases together with a comment for the reason of approval / denial / request. They can enable a chosen LMS if and whenever they need, and all the approved students will get automatically access to the LMS.

With this scenario, only students who have special requests will end up waiting for processing, review by an administrative staff or a professor. Most other students will be processed by the system automatically, as soon as the requested time slots are added by the administrators for class timetables and they enter the group. Even if some students experience a very long process of approval, the professors will have these students in their list together with their request and intermittent comments from the administrative staff, so will be able to take them into account in the course-work.

There will not be any conflicts or exemptions from attendance, unless deliberate and approved by the professors or supervisor. There will no other exceptions unless approved by the administrator for enrolments, professors or supervisor.

The architecture that will encompass all the data related to the term enrolment and course enrolment is presented in Figure 5, with most significant classes being from left to right: the four enrolment classes on the left detailing all the steps in the enrolment of a student to various detail, and then the rest of the diagram are all the course offerings. The complexity of that part is due to the intricacies of the enrolment model. Subject is in the top right representing all the subject areas for teaching, and each subject is than offered in some term via the class TermSubject. The subject can further be offered to special curriculum cases with modifications of the content or prerequisites or number of lecture hours, via the class TermSubjectCurriculumLink. The bottom right of the diagram groups the classes related to the Course instance, for which curricula it should be offered in general and finally to which of the offerings it should be relevant in this term.

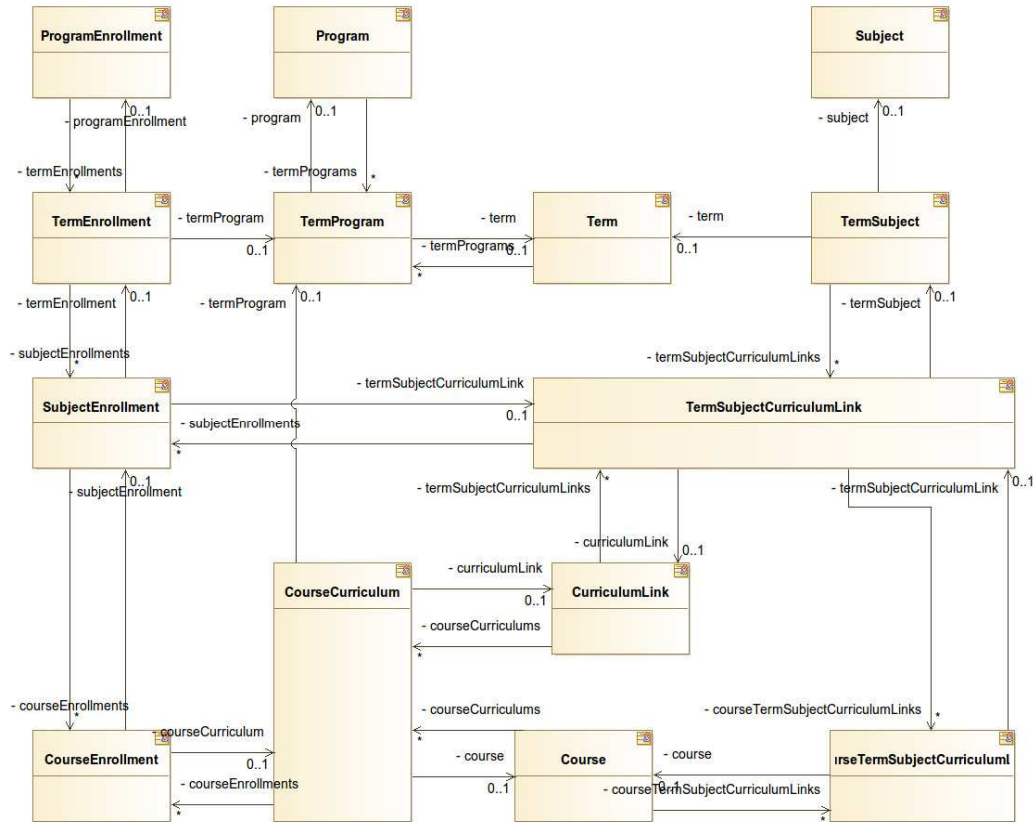

Figure 5. The class architecture for the enrolment

## 6. CONCLUSION

The proposed solution enables the university to go through a single unifying process that covers both the course enrolment and class timetable scheduling processes. It is expected from the solution to streamline both processes into a fully integrated system that will work on overall system improvement in several aspects:

- ◆ It is expected that the new system will not have timetable conflicts that are not deliberate;
- ◆ The relevant staff will have first hand information on conflicts that have occurred and the reasons for that;
- ◆ the student will not be left with a huge list of courses to choose from, but will be given a prioritized list depending on the values they have chosen to be relevant for them

## ACKNOWLEDGEMENTS

This paper is the result of a research conducted within the project ISISng (see [7]), which was partially financed by the Faculty of Computer Science and Engineering.

## REFERENCES

- [1] Ajanovski, Vangel V., (2010) "IS for Students by the Students", *Proceedings of the 7th International Conference for Informatics and Information Technology (CIIT 2010)*, Institute of Informatics, Skopje, Macedonia, pp 129, ISBN 978-9989-668-88-3.
- [2] Ajanovski, Vangel V., (2011) "Towards a Virtual Academic Adviser", *Proceedings of the 8th International Conference for Informatics and Information Technology (CIIT 2011)*, Institute of Informatics, Skopje, Macedonia, pp. 146-149. ISBN 978-9989-668-90-6.
- [3] O'Mahoney Michael and Smyth Barry (2007), A Recommender System for On-line Course Enrolment: An Initial Study, *RecSys'07, Minneapolis, Minnesota, USA*, ACM 978-1-59593-730-8/07/0010, pp. 136-137.
- [4] Romero Cristobal and Ventura Sebastian, (2010), Educational Data Mining: A Review of the State of the Art, *IEEE transactions on systems, man and cybernetics. Part C, Applications and reviews*, Vol. 40, No. 6, pp 601-618.
- [5] Aher Sunita and Lobo Louis, (2012), Applicability of Data Mining Algorithms for Recommendation System in E-Learning, *ICACCI '12, CHENNAI, India*, ACM 978-1-4503-1196-0/12/08, pp 1034-1040.
- [6] Easyrec, <http://www.easyrec.org/>
- [7] ISISng, <http://develop.finki.ukim.mk/projects/isis>

## Authors

**Vangel V. Ajanovski** is a teaching assistant at the Faculty of Computer Science and Engineering. In the period 2005-2009 he was the head of the computing centre and led the development of the information system. He has been working on information system process improvements in student information systems for 20 years.

